

ZCA16-0002 CITY OF CHANDLER / SIGN CODE AMENDMENT (“redlined” version)

City initiative to amend Chapter 39 (Sign Code) of the Chandler City Code by adopting a revised Chapter 39, in its entirety. Questions or comments may be directed to David de la Torre, Principal Planner with the City of Chandler, at 480-782-3059 or david.delatorre@chandleraz.gov.

Draft date: April 19, 2017

Revisions Key:

Regular text = Existing code

Underlined text = Proposed new text

~~Strike through text~~ = Proposed deletions

Chapter 39 - SIGN CODE

39-1. Findings and Purpose.

Signs can obstruct view, distract motorists, obstruct pedestrian and/or vehicular traffic flow, create a safety hazard, create aesthetic blight and visual clutter, and pose other problems that legitimately call for regulation. The purpose of this chapter is to regulate the size, color, illumination, movement, materials, location, height and condition of signs as defined herein displayed for exterior observation, in order to allow and promote sign communication in such a manner that:-

- A. ~~To p~~Preserves and protects the public health, safety and welfare within the City of Chandler.
- B. ~~To e~~Encourages development of private property in harmony with the desired character of the City while providing due regard for the public and private interests involved.
- C. Protects and improves the aesthetic beauty of the City’s built environment by eliminating aesthetic blight and reducing visual clutter.
- ~~CD. To p~~Promotes the effectiveness of signs by preventing their over-concentration, improper placement, and excessive size.
- ~~DE. To p~~Protects the general public from damage and injury which may be caused by the faulty and uncontrolled construction of signs within the City of Chandler.
- ~~EF. To p~~Protects pedestrians and motorists of the City of Chandler from damage or injury caused, or partially attributable to the distraction and obstructions which are hereby declared to be caused, by improperly situated signs.
- ~~FG. To e~~Enhances the flow of traffic and convenience, ease and enjoyment of travel within the City of Chandler.

39-2. - Interpretation of chapter.

- A. Where there is a conflict between the provisions of this chapter and provisions of other regulations of the City of Chandler, the provisions of this chapter shall apply.
- B. The provisions of this chapter shall apply to the erection, construction, alteration, ~~use,~~ location, and maintenance of all signs within the City of Chandler except as specified in Section 39-5.
- C. Any sign permitted by this chapter may contain a non-commercial message in lieu of any other message.

ZCA16-0002 City of Chandler / Sign Code Amendment (“redlined” version)

Draft date: April 19, 2017

D. Any provision of this Sign Code that imposes a limitation on freedom of speech shall be construed in a manner that is viewpoint neutral and treats expressive speech either the same as or less restrictive than commercial speech. Any provision of this Sign Code that is found to be an unconstitutional limitation on freedom of speech by any court shall be severed from this Sign Code in a manner that preserves the Sign Code and protects freedom of speech.

39-3. - Definitions.

~~*Appraiser:* Any licensed person, firm or corporation whose primary occupation or service is the erection, installation, renovation or alleviation of signs in the State of Arizona.~~

Balloon, common party: A common party balloon is a bag made of thin rubber or other light material that when fully inflated does not exceed three (3) feet in diameter. Common party balloons are typically inflated with air or gas that is lighter than air and tethered with a string or thin rope.

Balloon, fixed: A fixed balloon is any lighter-than-air or gas-filled balloon that is greater than three (3) feet in diameter when fully inflated and is attached by a tether to a fixed place and elevated to a height that is greater than fourteen (14) feet in order to attract attention to the business or property.

Banner: A temporary sign of fabric, plastic, paper or other flexible substrate on which copy or graphics may be displayed. Detached banners are not attached to a building and are secured to a freestanding temporary support structure, uprights, stakes or poles. Vertical banners are those that are affixed to a permanent structure such as a light pole within permitted outside display areas. For vertical banners that are mounted in-ground or on top of the ground see the definition for feather signs. ~~light pliable material not enclosed in a rigid frame, and mounted so as to allow movements of the sign by atmospheric conditions.~~

Billboard: A permanent sign structure portraying information not related to an event, business, commodity, product, service, or entertainment or product existing or occurring on the premises upon which the sign is located.

Block: At least seven hundred (700) feet of street frontage, including rights-of-way.

Building Code: Chapter 29 Building Regulations of the City Code.

Building envelope: The exterior area located within twenty (20) feet of the front of a building. Said area is typically designed for pedestrian use and may include features such as a sidewalk or colonnade parallel to the building front, the primary business entrance, signs, sidewalk furniture and planters.

~~*Building front foot:* The distance measured along the property line on which the lot fronts. In the event that a building fronts on two (2) or more streets, one (1) of which is primarily residential, the property owner shall be given the option of selecting one (1) street frontage for the purpose of computing allowable sign area. For corner lots abutting arterial streets, the owner may use both streets for computing sign area.~~

Business frontage-foot: For single tenant buildings the business frontage is the lineal distance of the building measured along a straight line parallel to the street. Where said building is not parallel to the street, the business frontage shall be measured along the exterior front wall of the building. For an individual business located within a multi-tenant building, the business frontage shall be the length of the space occupied by said business measured in a straight line along the exterior front wall of the building, except for an individual business with minimal exterior frontage occupying the interior corner space of an "L" shaped multi-tenant building, in which case the business frontage may be determined by the length of the space occupied by the individual business measured in a straight line parallel to the nearest street. The lineal distance of a building measured along a straight line parallel to the street. Where a building is not parallel to the street, the business frontage foot shall be measured along the exterior front wall of the building.

~~*Business, outdoor type:* A business in which all or most of the business is conducted or items displayed in an open area subject to the zoning codes of the City of Chandler.~~

ZCA16-0002 City of Chandler / Sign Code Amendment (“redlined” version)

Draft date: April 19, 2017

~~*Curbline:* The line at the face of the curb nearest the street or roadway. In the absence of a curb, the curbline shall be determined by the City Engineer.~~

Day: Unless otherwise specified, a day shall mean calendar day.

Fascia: A parapet-type wall used as part of the fascia of a flat-roofed building and projecting not more than six (6) feet from the building face. Such a wall shall enclose at least three (3) sides of the project flat roof and return to a parapet wall or the building.

~~*Grand opening:* The introduction, promotion or announcement of a new business, store, shopping center or office, or the announcement, introduction or promotion of the changing of ownership of an established business.~~

Ground level: The finished grade of existing sidewalk; or where there is no sidewalk, the street centerline elevation shall be the established ground level.

Halo: See definition for internal indirect lighting.

~~*Height of sign:* The distance measured from ground level to the top of the sign.~~

Indirect lighting: A source of external illumination located a distance away from the sign, which lights the sign, but which is itself not visible to persons viewing the sign from any normal viewing position.

~~*Internal lighting:* A source of illumination entirely within the sign which makes the contents of the sign visible at night by means of the light being transmitted through a translucent material but where in the source of the illumination is not visible.~~

Internal indirect lighting: A source of illumination entirely within the sign visible at night by means of lighting the background upon which the freestanding character is mounted. The character itself shall be opaque, and thus will be silhouetted against the background. The source of the illumination shall not be visible.

Institutional: See definition for quasi-public.

Maintenance: The replacing or repairing a part or portion of a sign made unusable by ordinary wear or tear, not exceeding fifty (50) percent of the sign's value, as determined by ~~an appraiser~~ a licensed sign contractor.

~~*Marquee:* A permanent roofed structure attached to and supported by the building and projecting over public property.~~

~~*Multiple tenant commercial building:* A commercial building or development in which exists two (2) or more separate commercial activities, where appurtenant shared facilities exist (such as parking or pedestrian mall, and which is designed to provide a single area in which the public can obtain varied products and services). Distinguishing characteristics may but need not include common ownership of the real property, common wall construction or multi-occupant commercial use of a single structure.~~

Model home cluster: A group of two (2) or more model homes (including the parking area) located next to each other, or on opposite sides of the same street that share a common sales office.

Non-commercial message: A message that does not propose a commercial transaction.

Parapet wall: An exterior wall of a building extending above the ~~plat the roof line~~ of the building.

Panel: The portion of a freestanding monument sign that is reserved for use by a single business, organization or other entity that is located in a commercial or industrial center. Panels can be replaced without replacing or modifying the entire freestanding sign structure.

ZCA16-0002 City of Chandler / Sign Code Amendment (“redlined” version)

Draft date: April 19, 2017

Public right-of-way: Any highway, street, road, lane, thoroughfare, avenue, boulevard, path, alley or other right-of-way that is maintained for public use and is publicly accessible. Public right-of-way does not include access easements on private property or any privately owned street, road, driveway, path or other similar passageway that may be connected to a public right-of-way. Public right-of-way typically includes sidewalks and landscaping on both sides of a street.

Quasi-public: Essentially public (as in services rendered) although under private or non-profit ownership or control. Quasi-public and institutional uses include educational institutions, medical institutions, religious institutions, fraternal organizations, civic organizations, and other similar uses.

Reverse pan channel: A three-dimensional letter or other sign component with opaque face and side walls and an open or translucent back that faces the wall on which it is mounted, concurrently blocking view of the light source within and allowing the wall behind to be illuminated, creating a halo effect around the letters or sign components.

Roof line: The height of the main roof structure but not to include cupolas, pylons, projections or other minor raised portions of the roof.

Seasonal decorations: Temporary decorations displayed around a holiday.

Sign: Any visual communications which is used to attract the attention of the public, when the display is visible beyond the boundaries of the property.

Sign, abandoned: A sign structure that is vacant, unoccupied, devoid of any message, or a sign that displays a message pertaining to a time, event, or purpose that no longer applies. ~~A sign which no longer correctly directs or exhorts any person, nor advertises a bona fide business, lessor, owner, product, or activity currently being conducted or product currently available.~~

Sign, A-frame: A type of temporary sign that is portable, self-supporting, and consists of a structure that resembles an “A” shape.

Sign, air-activated: Air-activated signs are temporary signs which include common party balloons, inflatable figures, balloon sculpture/arches, air-dancers, wind-driven spinners, pennants, streamers, and other figures or graphics that are filled with air or a gas that is lighter than air, or move with natural or artificially generated air flow, all of which are typically used in conjunction with a special event or activity.

Sign area: ~~The entire area within a single continuous perimeter of the sign or any existing border of the sign; to exclude the necessary supports or uprights on which the sign is placed. In any event, composition of allowable sign area includes all existing signs on the premises, whether such signs be conforming or nonconforming under the terms of this chapter. Where a sign is double-faced or V-shaped, only the larger single face shall be used to determine sign area.~~

Sign, awning: A permanent sign that is a part of or attached to an awning, canopy, or other fabric, plastic, or structural protective cover over a door, entrance, window, or outdoor service area.

Sign, blade: A blade sign is a type of projecting sign mounted on a building façade, storefront pole, hanging from a roof overhang or colonnade, or attached to a surface perpendicular to the normal flow of traffic. A blade sign may be referred to as a hanging blade sign or a projecting blade sign depending on the manner in which it is attached to the building or other structure.

Sign, cabinet: A permanent sign that is internally illuminated in which a removable sign face, usually with translucent sign graphics, is enclosed on all edges by a cabinet, and the source of illumination is not visible. A cabinet sign may be multi-faced.

Sign, change panel: A permanent sign designed to permit immediate change of copy, ~~which may be other than the name of the business.~~

ZCA16-0002 City of Chandler / Sign Code Amendment (“redlined” version)

Draft date: April 19, 2017

Sign, digital: A permanent sign with an electrically activated changeable sign face whose variable message and/or graphic presentation capability can be electronically programmed by computer from a remote location. Digital signs may also be known as Electronic Message Centers or EMC.

~~Sign, directory:~~ A sign designed to show the relative locations of tenants in the shopping center or other multi-tenant development and/or building.

Sign face: The entire display surface area of a sign upon, against or through which copy, symbol or similar component is placed.

Sign, feather: A type of temporary sign made of flexible material that is plain or includes copy and/or graphics and is supported by a vertical pole that is anchored in or on the ground. Such signs may also be referred to by other names such as feather flag, feather banner, teardrop flag, shark fin flag, blade flag, or bow sign.

Sign, freestanding monument: A permanent sign that is supported by one (1) or more uprights, or poles, a base or other similar structural foundation that is ~~and~~ braced in or upon the ground, is detached from any other structure or building, and is typically between six (6) feet to fourteen (14) feet in height.

~~Sign, low-profile:~~ A sign not exceeding a six-foot height above ground level.

Sign, illegal: Illegal signs include any sign except the following:

- A. A sign allowed by this chapter and not requiring a permit.
- B. A sign allowed by this chapter with a permit and carrying a valid permit.
- C. A sign not allowed by this chapter but which has been legalized by PAD zoning or variance and proper permit.
- D. A sign allowed by this chapter subject to a use permit, provided the use permit has been granted and a proper permit is in force.
- E. A nonconforming sign as defined by this chapter.

Sign, nonconforming: Any permanent sign which is not permitted by this chapter, but which, when first constructed, was legally permitted by the City or the political subdivision then having jurisdiction and regulation over construction of signs.

~~Sign, on-site:~~ A sign which correctly identifies a business, commodity, service or entertainment conducted, sold or offered on the same premises as those upon which the sign is located, whether an attached sign or freestanding sign, and which may include other nonchangeable information that further identifies the type of business, commodity, service, or entertainment offered therein, including addresses and phone numbers.

Sign, permanent: Any sign constructed and intended to be of an enduring and lasting condition, remaining unchanged in character, condition (beyond normal wear) and position.

~~Sign, portable:~~ Any sign not permanently attached to the ground or to a structure on the property it occupies.

Sign, projecting: Any permanent sign attached to a building or other structure in such a manner that its face is not parallel to the wall and is extending in whole or in part beyond the building line (e.g., hanging or projecting blade signs).

Sign, T-frame: A type of temporary sign that is portable, self-supporting, and consists of an upright component that is attached to a flat base, which resembles an upside-down “T”.

ZCA16-0002 City of Chandler / Sign Code Amendment (“redlined” version)

Draft date: April 19, 2017

Sign, temporary: Any sign not permanently embedded in the ground or not permanently affixed to a building or structure, which is not intended to be a long lasting permanent sign. Temporary signs include signs affixed to the ground by a temporary anchoring system such as, but not limited to, stakes or ballast, or footing for large temporary freestanding signs. ~~, banner, pennant, valance or advertising display constructed of cloth, canvas, light fabric, cardboard, wallboard, or other like materials, with or without frames, intended to be displayed for a short period of time as defined in this chapter.~~

Sign, temporary freestanding: A temporary sign that is made of a rigid and durable material that will withstand the elements, is supported by one (1) or more posts, uprights or poles and is braced in or upon the ground. Each temporary freestanding signs may be single-faced, double-faced, or V-shaped with an interior angle that is 45 degrees or less as provided for in subsection 39-7.9(A)3.

Sign, V-shaped: Signs erected upon common or separate structures which present a V-shape appearance and having an exterior angle between faces of not more than forty-five (45) degrees with a distance between faces of such signs at their closest point not exceeding two (2) feet.

Sign, vehicle: Any sign mounted or painted upon or otherwise erected on a trailer, truck, automobile or other vehicle, ~~so parked or placed so that the signs thereon are visible from a public street or right-of-way.~~

Attached Sign, wall: Any sign which is attached, fastened, connected or supported in whole or in part by a building or structure other than a freestanding sign structure which is supported wholly by the ground. Wall signs include wall mounted signs, projecting signs, awning signs and window-mounted signs. A window-mounted sign is not a window sign as defined herein.

Sign, window: Any permanent sign affixed to, painted on or adhered to the interior or exterior of a glass door or window or placed inside a glass door or window and is visible from the exterior of the window. ~~so as to attract the attention of persons outside the building.~~

Sign, Yard: A type of temporary sign that is typically less than six (6) square feet in area and is supported by one or more stakes or metal wires inserted into the ground. The sign face is typically made of a semirigid material such as corrugated plastic, sheet metal, foam board, cardboard or placard. Yard signs may also be referred to by other names including lawn signs, road signs, bandit signs, or placard signs.

Uniform Building Code: The edition of the Uniform Building Code adopted for use by the City.

~~V/C case type materials: Those which have a flame spread rating of two hundred twenty five (225) or less when tested in accordance with Uniform Building Code Standard No. 42-1 in the way intended for use or a smoke density rating no greater than seventy five (75) when tested in the thickness intended for use by the Chamber Method of Test under Uniform Building Code Standard No. 52-2. The products of combustion shall be no more toxic than those of untreated wood when burned under similar conditions.~~

Zoning Administrator: The person appointed and responsible for the enforcement of the Sign Code, or said person's designee.

39-4. - Requirement of conformity; ~~violations and penalties.~~

Unless specifically exempted herein, no sign shall be erected, installed, enlarged or maintained without first obtaining a permit from the City as herein provided. It shall be unlawful for any person, firm or corporation to erect, construct, enlarge, alter, repair, move, improve, remove, convert, demolish, equip, use or maintain any sign or structure in the City, or cause or permit the same to be done contrary to or in violation of any of the provisions of this chapter. A.—All signs maintained contrary to the provisions of this chapter are declared to be nuisances, and such nuisances may be abated as provided by law.

~~B. Any person, firm or corporation violating any provision of this chapter or failing to comply with any order or regulations made hereunder shall be guilty of a misdemeanor and shall be guilty of a separate offense for each and every day or portion thereof during which any violation or failure to~~

ZCA16-0002 City of Chandler / Sign Code Amendment (“redlined” version)

Draft date: April 19, 2017

~~comply with this chapter is committed, continued or permitted. Upon conviction of any such violation, such person shall be subject to the penalties as set forth in Chapter 1 of the City Code.~~

39-5. - Nonconforming and abandoned signs.

A. Any nonconforming sign, as defined in this chapter, may be continued in use and reasonable repair and maintenance made to same.

B. Any nonconforming sign shall not be altered, repaired, or restored to such an extent that the cost of such alteration, repair or restoration exceeds fifty (50) percent of the sign's value, as determined by a licensed sign contractor, unless said sign is brought into conformance with the current provisions of this Code.

BC. If any such Any nonconforming sign that is damaged or vandalized, such sign must be restored in a like manner within ninety (90) days or it shall be removed or replaced with a new sign that is in conformance with the current provisions of this Code at the owner's expense. A permit may be required depending on the scope of work

D. Any sign (including nonconforming) that has been abandoned for more than ninety (90) days shall be removed or replaced with a new sign in conformance with the current provisions of this Code at the owner's expense.

E. A permit may be required for alterations or repairs to nonconforming signs that do not exceed fifty (50) percent of the sign's value depending on the scope of work (e.g. an electrical permit shall be required for signs that are illuminated electrically). Alterations or repairs to nonconforming signs that exceed fifty (50) percent of the sign's value shall require permit as provided for in section 39-7.

39-6. - Enforcement.

~~A. Authority.~~ The Zoning Administrator or designee is hereby authorized and directed to enforce all provisions of this chapter in conformance with the regulations and procedures specified herein, ~~in conjunction with the provision of the Chandler Zoning Code.~~

B. Each day a violation of any provision of this chapter or the failure to perform any act or duty required by this chapter continues shall constitute a separate violation or offense.

C. The City may proceed either civilly or criminally against any person responsible for causing, permitting, facilitating, or aiding or abetting any violation of any provision of this chapter or for failing to perform any act or duty required by this chapter.

D. When two (2) or more persons have liability to the City or are responsible for a violation of this chapter, their responsibility shall be joint and several.

39-6.1 - Civil Citations.

A. Any continuing violation of this chapter constitutes a public nuisance and may result in the issuance of a civil citation by the City as set forth in Chapter 26 of this Code. Imposition of a fine or penalty assessment shall not relieve the owner of the responsibility for abatement of the violation(s) or excuse him/her from liability for any and all costs incurred by the City for abatement.

B. Any person who commits a violation of a provision of this chapter after previously having been found responsible for committing two (2) or more civil infractions of this chapter within any thirty-six (36) month period, whether by admission, by payment of the fine, by default, or by judgment after hearing, shall be guilty of a criminal misdemeanor punishable as set forth in Subsection 1-8.3 of this Code. The Chandler City Prosecutor is authorized to file a criminal misdemeanor complaint in the Chandler Municipal Court against such habitual offenders who violate this Section. For purposes of calculating the thirty-six (36)

ZCA16-0002 City of Chandler / Sign Code Amendment (“redlined” version)

Draft date: April 19, 2017

month period under this paragraph, the dates of the commission of the offenses are the determining factor.

39-6.2 - Criminal Complaints.

A. The Zoning Administrator or any other City agent or employee duly authorized may seek the issuance of a complaint in the Chandler Municipal Court by a police officer or the Chandler City Prosecutor for criminal prosecution of any person who fails to perform any act or duty required by this chapter.

B. Criminal action and proceeding under this chapter shall be designated a misdemeanor and shall be commenced and prosecuted, and is punishable as set forth in Subsection 1-8.3 of this Code in accordance with the laws of the State of Arizona relating to misdemeanors and the Arizona Rules of Criminal Procedure.

39-6.3.11. - Revocation of permits.

The Zoning Administrator shall have the authority to revoke any permit which has been granted when it has been determined by the ~~Director of Planning and Development~~ or the Zoning Administrator that the sign authorized by the permit has been constructed or is being maintained in violation of the permit.

A. Notice of the ~~planning and development~~ Zoning Administrator's decision to revoke a sign permit shall be served on the holder of the permit by:

1. Delivering a copy of the notice to the holder of the permit, mail return receipt requested, to the last-known post office address of the holder of the permit; and
2. Leaving a copy of the notice with any person in charge of the premises and a copy mailed to the property owner; or
3. In the event no such person can be found on the premises, by affixing a copy of the notice in a conspicuous position at or near the entrance to the premises.

B. The holder of the permit may appeal the decision of the ~~Director of Planning and Development~~ Zoning Administrator to the Board of Adjustment. This appeal must be made within thirty (30) days from the date when the notice was served.

C. If no appeal has been filed by the end of the thirty-day appeal period, then the permit is revoked and the sign is illegal. The ~~Director of Planning and Development~~ Zoning Administrator shall then initiate the procedure for the removal of the illegal sign.

39-6.4. 12. - Removal of signs.

The ~~Director of Planning and Development~~ Zoning Administrator is hereby authorized to require the removal of any illegal sign as defined by this chapter.

A. Before bringing action to require the removal of any illegal sign, except as noted hereafter, the ~~Director of Planning and Development~~ Zoning Administrator shall give written notice to the owner of the sign or the owner of the premises on which the sign is located. The notice shall state the reasons for removal, listing the deficiencies or defects in the sign with reasonable definiteness, and the violations charged. The notice shall include what repairs if any will make such an installation conform to the requirements of this chapter. The notice shall specify that the sign must be removed or made to conform with the provisions of this chapter within the time period listed below. ~~Service of notice may be given personally to the owner or lessee, or by certified mail addressed to the owner or lessee at the address specified in the permit or last-known address.~~ Service of the notice shall be by any of the following methods:

ZCA16-0002 City of Chandler / Sign Code Amendment (“redlined” version)

Draft date: April 19, 2017

1. Delivery in person to the owner, occupant, manager or agent of the premises where the violation has occurred, or to the person responsible for the violation;

2. Posting on or about the entrance of the premises where the violation occurred;

3. By first class mail, postage prepaid, addressed to the owner, occupant, agent, manager or responsible person at the last known address. Service by mail is deemed complete upon deposit in the U.S. mail;

4. By Certified mail;

5. By publication; or

6. By serving the owner, occupant, manager, agent, or responsible person in the same manner as provided by the Arizona Rules of Civil Procedure.

B. The Zoning Administrator shall not be required to give written notice before removing or bringing action to require the removal of any illegal yard sign or illegal temporary sign attached to any public facility such as government signs and supporting poles, utility poles, street lights, light poles, and trees on public property.

B C. The period of notice for permanent signs as defined by this chapter shall be thirty (30) days. The period of notice for temporary signs as defined by this chapter shall be three (3) working days.

C D. The re-erection of any sign or substantially similar sign on the same premises after a removal notice has been issued shall be deemed a continuance of the original violation.

D E. If the owner or lessee of the premises where the sign is located has not complied with this chapter by the end of the notice period, the ~~Director of Planning and Development~~Zoning Administrator may pursue enforcement as authorized by this chapter. ~~shall certify the violations to the City Attorney for prosecution or any other remedy allowed by law.~~

39-6.5. 13- - Emergency removal or repair.

A. The ~~Director of Planning and Development~~Zoning Administrator is hereby authorized to cause the immediate removal or repair of any sign or signs found to be unsafe, defective, or a traffic hazard to the extent that it creates an immediate and emergency hazard to persons or property. Actual notice to the property owner or lessee shall not be required. The ~~Director~~Zoning Administrator shall make a reasonable effort to notify the property owner or lessee that the defective and unsafe sign must be removed or repaired immediately.

B. All actual costs incurred by the ~~Director of Planning and Development~~Zoning Administrator in the removal or repair of said sign shall be paid by the owner of the sign or the owner of the premises where the sign is located. Action for recovery may be brought by the City Attorney upon proper certification to him/her by the ~~Director of Planning and Development~~Zoning Administrator.

39-7. - Requirements and procedures.

39-7.1 Permits required. No sign shall hereafter be erected, reerected, constructed or altered except as provided by this chapter. A separate permit shall be required for a sign or signs for each business entity, and/or separate permit shall be required for each group of signs panels on a single supporting structure. Said permits may include structural, electrical or other plan review as determined by ~~Where signs are illuminated electrically, a separate electrical permit shall be obtained as required by the Electrical Code~~Chapter 29 Building Regulations of the City Code.

39-7.2 Exceptions. A sign permit shall not be required for the following signs; however, such signs shall be subject to any and all applicable provisions of the City Code, including this chapter:

ZCA16-0002 City of Chandler / Sign Code Amendment (“redlined” version)

Draft date: April 19, 2017

- A. ~~Nameplate signs.~~ Signs required under subsection 39-7.7.
- B. Any sign six (6) square feet or less in area not otherwise prohibited or required to obtain a permit by this chapter.
- C. Repainting.
- D. Temporary signs erected that are associated with a Special Event Permit in accordance with Chapter 32 of this Code. ~~Signs erected during the Christmas holidays as identification of temporary sales areas for Christmas trees and other holiday oriented items; such signs shall not be erected before Thanksgiving and shall be removed within ten (10) working days after New Year's Day and shall only be erected in accordance with a special event permit in accordance with Chapter 32 of this Code.~~
- E. ~~Signs erected and maintained during the month of October as identification of temporary sales areas for pumpkins. Such signs shall only be erected in accordance with a special event permit in accordance with Chapter 32 of this Code.~~ F. ~~Political signs, as permitted in Section 39-10.8.~~
- ~~GE.~~ Interior signs not visible from the public right-of-way or which are not visible from one property to another, except when said signs require a permit as provided by this chapter.
- ~~HF.~~ Grand opening signs as provided for in Section 39-10.5. Vehicle signs as provided for in subsection 39-7.8(D).
- G. Window signs as provided for in section 39-9.14.
- H. Temporary signs identified in section 39-10 as not requiring a permit.
- I. Seasonal decorations.
- J. Normal repair and maintenance of conforming or nonconforming signs that does not exceed fifty (50) percent of the sign's value, as determined by a licensed sign contractor.
- K. Government signs: Nothing contained herein shall prevent the erection, construction, and maintenance of official ~~traffic, fire and police signs, signals, devices, and markings~~ signs of the State of Arizona and the City of Chandler, or other competent public authorities, or the posting of notices required by law.
- L. Signs protected by state statutes: Nothing contained herein shall prevent the erection, construction, and maintenance of signs authorized and/or protected by Arizona Revised Statutes.

39-7.3 Permit application and expiration.

A. Application. Applicants may apply for a sign permit or a temporary sign permit by completing and submitting a permit application provided by the Planning Division together with required plans and/or details identified by said application. shall be made in writing upon forms provided by the building inspections division. This application shall contain the location by street and number of the proposed sign, as well as the name and address of the business owner and/or the sign contractor. Two (2) copies of plans and specifications shall be submitted with the application for each sign, one (1) copy being returned to the applicant at the time the permit is issued. All plans submitted with the application shall show complete details, to include size, materials, method of support or attachments, name and address of the persons or firm designing said sign and plot plan showing location of sign on the premises. Permit review time frames shall conform to time frames adopted by the City as required by Arizona Revised Statutes which are posted on the City's website. An applicant may appeal a permit denial to the Board of Adjustment within thirty (30) days from the date of denial in accordance with the appeal procedure set forth in Section 35-2503 of the City Code.

ZCA16-0002 City of Chandler / Sign Code Amendment (“redlined” version)

Draft date: April 19, 2017

B. *Revocation of permits for nonuse.* If actual work is not commenced under any permit issued under the provisions of this section within ~~ninety (90) days~~ one (1) year from the date of such permit, such permit shall become null and void.

39-7.4 Permit fees. Before issuing any sign permit required by this chapter, the City shall collect a fee in accordance with the schedule adopted by Council ~~resolution~~:

39-7.5 Construction requirements. ~~A. Code conformance.~~ All signs shall be designed and constructed in conformance with ~~chapter 4, sections 401 and 402, and chapter 13, section 1301, of the Chandler Uniform Sign~~Building Code 1997 Edition, published by the International Conference of Building Officials, three (3) copies of which are on file with the City Clerk and which is hereby adopted by reference and made a part hereof as if set forth at length herein. In the event there is a conflict between the provisions of this chapter and those in the ~~Uniform Sign~~Building Code, the more restrictive provision shall apply.

~~B. Lighting.~~ When allowed, lighting shall not be installed so as to create a traffic hazard as determined by the traffic engineer.

39-7.6 Guy wires. In no case shall any sign be secured with wires or strips of wood which are visible and not on an integral part of the sign.

39-7.7-6 Design and Integration. All permanent signs shall be fully integrated with the design of the building and the site development, reflecting the architecture, building materials, and landscape elements of the project.

A. The means of integrating freestanding monument signs with the architecture of the building shall be achieved through replication of architectural embellishments, colors, building materials, texture, and other elements found in the building design. As an example, a ~~canister cabinet~~ sign mounted atop a masonry base or other fixture shall not be considered as integrated with the architecture of the building. Instead, where a ~~canister cabinet~~ sign is proposed as a component of a freestanding sign, such ~~canister cabinet~~ shall be bordered or backgrounded by the architectural materials and embellishments found within the building design.

B. Integration shall also include the use of sign graphics that are consistent in terms of lettering style, colors, and method of attachment as used for wall-mounted ~~signings~~signage found on the building.

C. Each unused panel on a freestanding monument sign shall have an integrated or decorative cover until said panel is utilized. ~~When mounted on a building, the sign shall be located on or below the fascia or parapet wall of the primary building;~~

D. When freestanding, the sign shall not exceed height standards set forth in section 39-9.16.

E. When mounted on a building, the sign shall be located on or below the fascia or parapet wall within the limits of the tenant’s occupied space.

F. Raceways shall be mounted behind the letters only, architecturally integrated and painted to match the building. ~~When freestanding, the sign shall not exceed six (6) feet in height except as provided in section 39-9.16. All freestanding signs shall be placed in conformance with Standard Detail No. 39, Sign Distance Standard, as adopted by the City of Chandler and administered by the City Engineer, so as not to impede traffic visibility at street corners and driveways.~~

G. In no case shall any sign be secured with wires such as guy wires or strips of wood which are visible and not on an integral part of the sign.

H. Signs shall be designed in coordination with landscape plans, planting materials, storm water retention requirements, and utility pedestals, so as not to create problems with sign visibility or prompt the removal of required landscape materials.

39-7.8 Prohibited lighting and movement.

ZCA16-0002 City of Chandler / Sign Code Amendment (“redlined” version)

Draft date: April 19, 2017

~~A. *Lighting sources.* No exposed incandescent bulbs exceeding forty (40) watts each, neon or similar tube type of illumination exceeding thirty (30) milliamps shall be permitted. No flashing, blinking or rotating lights shall be permitted, nor shall the sign contain audible sound or odor (excluding time-temperature signs).~~

~~B. *Action signs.* There shall be no movement of the sign body or any segment thereof such as rotating (in excess of five (5) revolutions per minute, moving up and down or any other type of action involving a change in position of the sign body or segment thereof, whether caused by mechanical or any other means.)~~

39-7.9-7 Required signs. Every building, including single-family homes or group of buildings must be identified by a street number.

39-7.10-8 Location restrictions for all signs (permanent and temporary).

A. *Clearance from fire escapes, exits or standpipes.* No sign or structure shall be erected in such a manner that any portion of its surface or supports will interfere in any way with the free use of any ~~fire escape, exit or standpipe, or any ingress or egress from any door, window, fire escape or any other exit~~ required by Building Code or Fire Department regulations.

B. *Obstructions of openings Vehicular and pedestrian traffic safety.* No sign shall obstruct traffic by obstructing the vision of motorists as determined by the Traffic Engineer. No detached sign shall be located adjacent to driveways so as to result in a traffic hazard. No sign shall obstruct minimum pedestrian clearance required by Americans with Disabilities Act or as required by this chapter whichever is greater.

C. *Signs on public property.* No person, firm or corporation shall erect or cause to be erected any sign which projects over any public sidewalk, street, alley or public place except for signs approved through a special event permit as provided for in Chapter 32 of the Chandler City Code and signs allowed in the public right-of-way as provided for in sections 39-7.8(E).

D. *Signs on vehicles.* The intent of these regulations is to prohibit the use of vehicle signs as permanent freestanding signs in order to protect the aesthetic qualities of the City’s built environment and promote the effectiveness of permitted signs as provided for in section 39-1. No sign shall be erected or attached to any vehicle except for ~~standard advertising or identification markings which are painted on or permanently attached to a business or commercial vehicles~~ signs that are magnetically attached to or permanently painted or wrapped on the surface of a vehicle. The primary use of such vehicles shall be in the operation of the business, e.g. transporting goods or providing services, and not in displaying a sign, advertising or identifying the business premises. Vehicles shall be operable and properly licensed. When not in use, the vehicle shall be parked in a lawful manner on the business property so as not to be visible from the public right-of-way, or if this is not possible, as far from the public right-of-way as possible.

Figure 7.8-D1

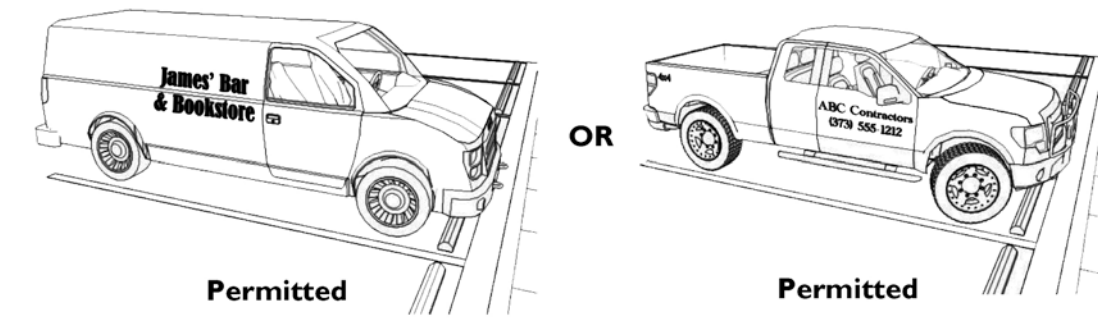

ZCA16-0002 City of Chandler / Sign Code Amendment (“redlined” version)

Draft date: April 19, 2017

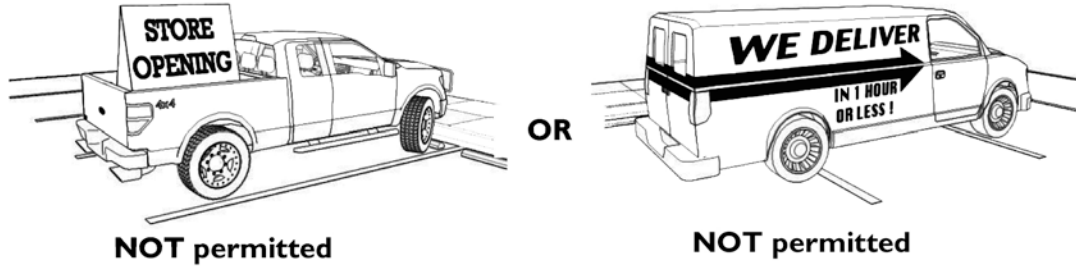

(Vehicle signs must be magnetically attached, permanently painted, or wrapped on the surface of the vehicle)

(Vehicles shall be parked in a lawful manner on the business property)

E. Signs in public right-of-way. The City of Chandler finds that a proliferation of signs in the public right-of-way creates aesthetic blight and visual clutter, which obstructs views, distracts the traveling public and threatens the public health, safety and welfare. The intent herein is to allow a limited number of signs in the public right-of-way in order to maintain safe visibility and protect the aesthetic beauty of the City’s built environment. As such, ~~None~~ no sign shall be erected or maintained in the public right-of-way except for:

1. Official bus stop advertising signs;
2. Permanent signs installed or displayed by a business or nonresidential use that occupies a building that fronts onto and abuts the public right-of-way as provided for in sections 39-9.13 Blade Signs and 39-9.18 City Center District;
3. Temporary signs expressly provided for in Section 39-10; hereafter in this chapter.
4. Official signs posted by the State of Arizona, the City of Chandler, or other public authorities;
5. The posting of notices required by law; and
6. Signs protected by Arizona Revised Statutes.

39-7.9 Sign Area and Height Calculations.

A. Sign area is calculated as follows:

1. Signs with backgrounds: Signs with copy mounted, affixed, or painted on a background panel or surface distinctively painted, textured or constructed as a background for sign copy, shall be calculated as that area contained within the smallest rectangle that encloses both the sign copy and the background, not including the supporting structure or architectural embellishments, as shown in Figure 7.9-A1.

Figure 7.9-A1

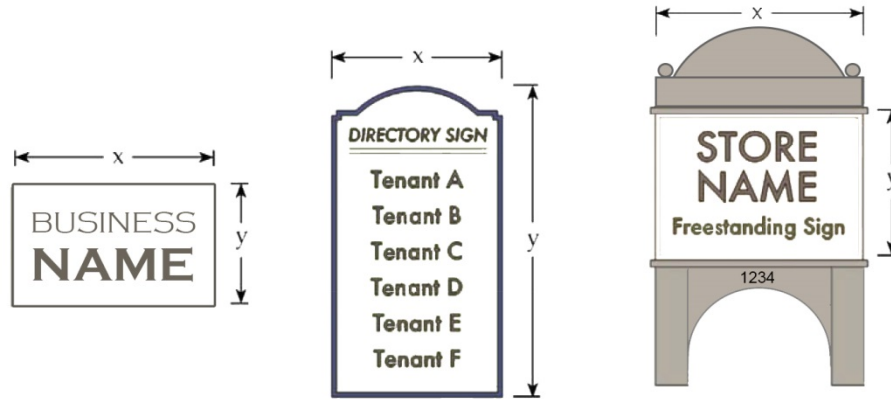

2. Signs with individual letters or graphics: The area for signs consisting only of individual letters, numerals, symbols, or other similar components shall be calculated as the area of a single rectangle that encompasses all sign components, as shown in Figure 7.9-A2.

Figure 7.9-A2



3. Two-face signs: Where a sign is double-faced, or V-shaped and the interior angle between the two sign faces is 45 degrees or less, only the larger single face shall be used to determine sign area. If the angle between the two sign faces is greater than 45 degrees, the sign area is the sum of the areas of the two sign faces, as shown in Figure 7.9-A3.

Figure 7.9-A3

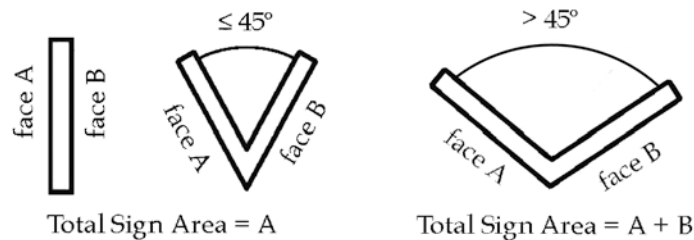

4. Three- or four-face signs: The sign area for three- or four-face signs shall be calculated as 50% of the sum of the areas of all sign faces, as shown in Figure 7.9-A4.

Figure 7.9-A4

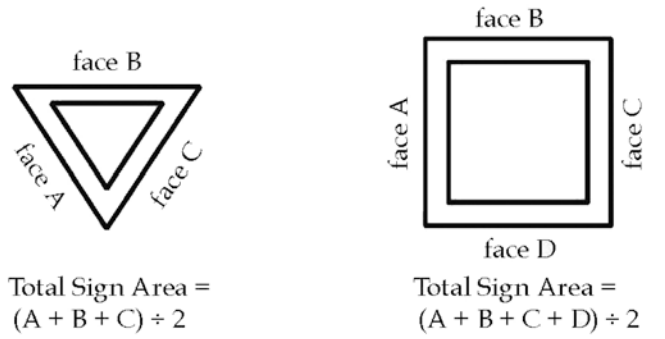

5. Spherical, free-form, sculptural or other non-planar signs: The area for non-planar signs shall be calculated as 50% of the sum of the areas using only the four vertical sides of the smallest four-sided polyhedron that will encompass the sign structure, as shown in Figure 7.9-A5.

Figure 7.9-A5

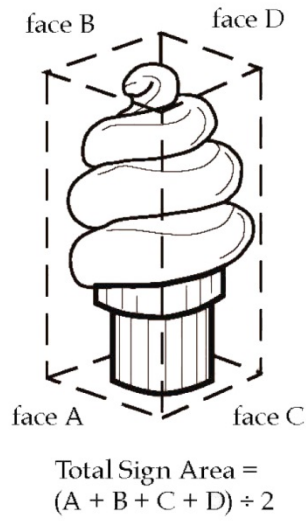

A. Sign height shall be measured as follows:

1. Freestanding Monument Signs: Sign height is measured as the vertical distance from ground level (finished grade of existing sidewalk, or where there is no sidewalk, the street centerline), to the top of the freestanding sign, not including architectural embellishments, as shown in Figure 7.9-B1.

Figure 7.9-B1

ZCA16-0002 City of Chandler / Sign Code Amendment (“redlined” version)

Draft date: April 19, 2017

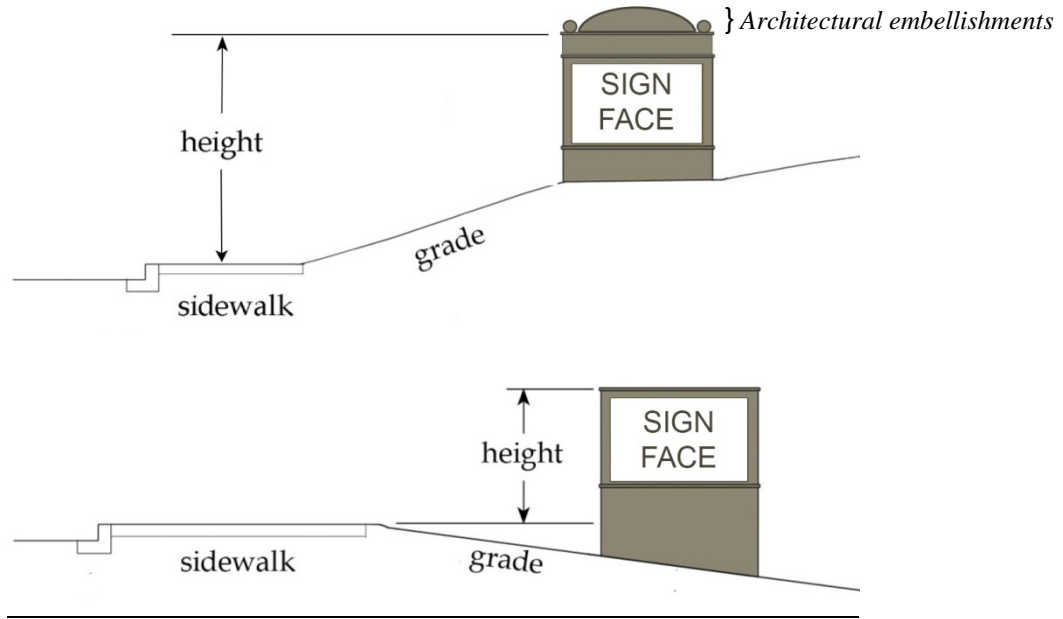

2. Wall Signs: The maximum height of wall, projecting, awning, fascia, mansard, parapet, window-mounted, or other building mounted signs is the vertical distance measured from the first floor elevation to the top of the sign or sign structure as shown in Figure 7.9-B2.

Figure 7.9- B2

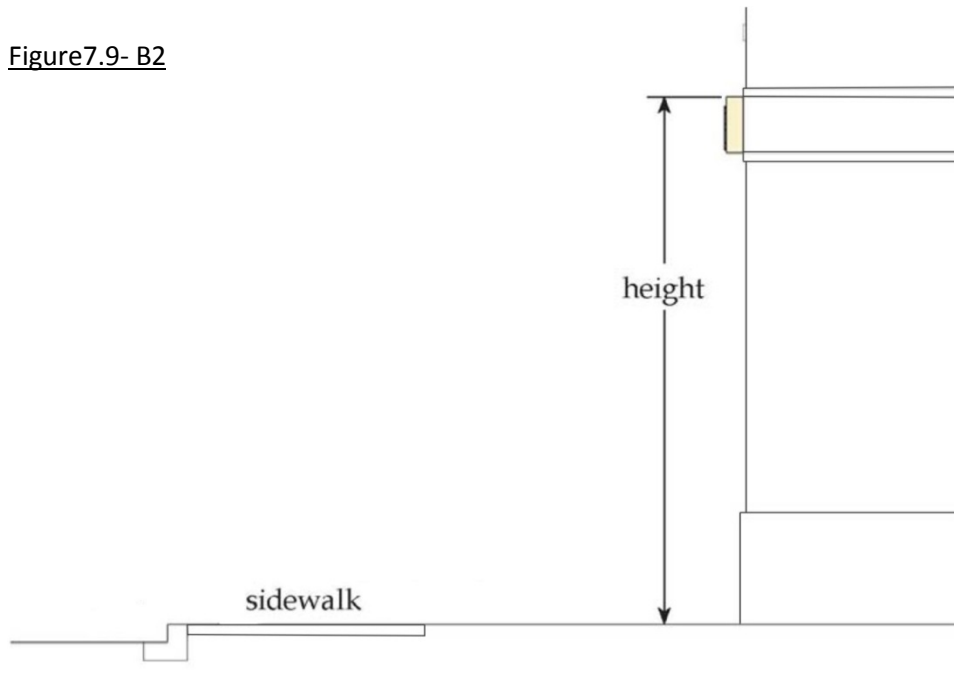

3. Blade Signs: The minimum clearance height of hanging blade signs and projecting blade signs is measured from finished grade/sidewalk to the bottom of the blade sign as shown in Figure 7.9-B3.

Figure 7.9-B3

ZCA16-0002 City of Chandler / Sign Code Amendment (“redlined” version)

Draft date: April 19, 2017

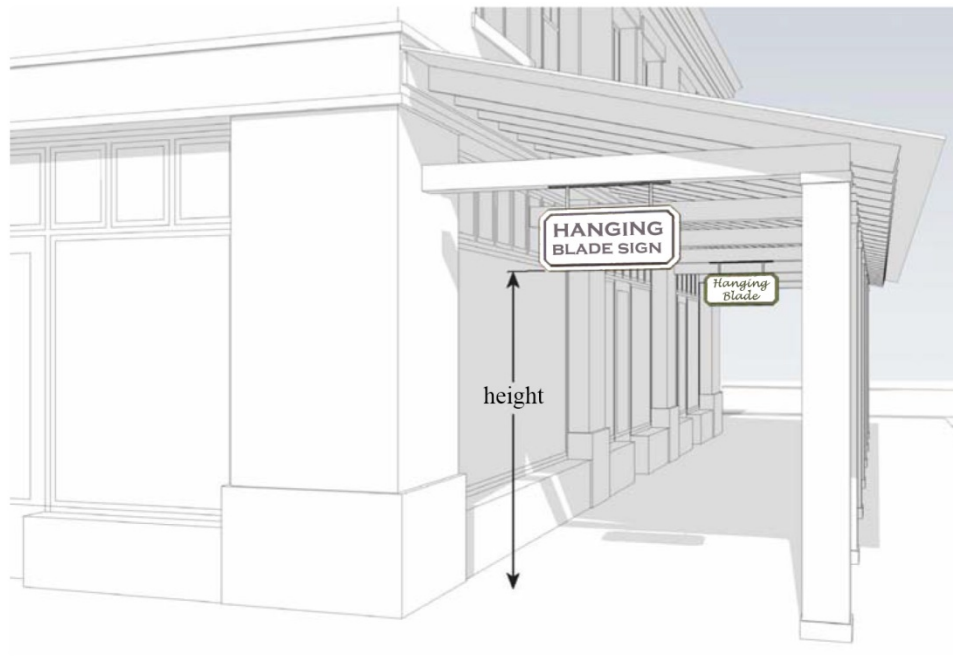

4. Temporary signs: The maximum height for all temporary signs is measured from the sidewalk to the highest point of any portion of the sign.

~~39-7.41-10~~ Inspections. All signs for which a permit is required shall be subject to the following inspections:

- A. Footing inspection on all freestanding signs exceeding fifty (50) square feet in area and/or exceeding thirty (30) inches in height.
- B. All signs containing electrical wiring shall be subject to the Electrical Code of the City and the electrical components shall bear the label of an approved testing agency.
- C. Inspection of all braces, anchors, supports and connections, including wall signs.
- D. Shop and/or site inspection to ensure that the sign has been constructed according to approved application and valid sign permit.

~~39-7.42-11~~ Identification.

A. All permanent signs regulated by this chapter shall be marked with the marker's name and the person or firm erecting such sign, the date of installation, and the permit number. This identification shall be permanently attached to the exterior surface of the sign in a location where the information will be readily visible, legible, and accessible after installation of the sign. ~~Such identification tags shall be furnished by the City.~~

B. Temporary signs, except for those not requiring a permit under section 39-10, shall be marked to show permit number and expiration date.

~~39-7.43-12~~ Maintenance. ~~Each~~ All signs shall be maintained in good order and repair at all times so that ~~it~~ they constitutes no danger or hazard to public safety.

39-8. - Prohibited signs.

- ~~A. Signs prohibited under this chapter include the following~~ The following signs are prohibited:

ZCA16-0002 City of Chandler / Sign Code Amendment (“redlined” version)

Draft date: April 19, 2017

1. ~~A. A frame signs and portable signs of any nature, other than those provided in section 39-10. Signs that pose a traffic hazard due to their position, size, shape, movement, coloring, or manner of illumination which may be confused as a traffic control device or which hide from view any traffic sign or signal; obstruct the view of motor vehicle operators entering the public right-of-way; or create an unsafe distraction or obstruction for motor vehicle operators;~~
2. ~~B. Outlining Signs that outline of a building by means of neon lighting, incandescent lighting or other exposed artificial lighting;~~
3. ~~C. A Fixed balloons used as a sign. (Means any lighter than air or gas filled balloon attached by a tether to a fixed place.);~~
4. ~~D. Signs over fourteen (14) feet in height. Signs that contain or consist of exposed incandescent bulbs exceeding forty (40) watts each, or neon or similar tube type of illumination exceeding thirty (30) milliamps, except as provided for in section 39-9.18 City Center District;~~
5. Signs which are abandoned for a period of ~~thirtyninety (3090)~~ thirty (30) days or greater;
6. Signs that have flashing, blinking, fluttering or rotating lights, lasers, or other illuminating devices which exhibit movement, except digital signs as provided for in section 39-9.15, or when approved for City sponsored public events, or through a special event permit as provided for in Chapter 32 of the Chandler City Code;
7. Signs that produce odor or audible sound;
8. Signs that contain mechanical movement or movement controlled by any other means, except for air activated signs as provided for in section 39-10 Temporary Signs;
9. Signs that are painted, attached or mounted on fuel tanks, storage containers and/or solid waste receptacles or their enclosures, except for those required by law;
10. Signs that are installed or displayed without the property owner’s approval; and
11. Billboards.

39-9. – Permanent signs permitted.

39-9.1 Single-family residential

A. Individual single family lots.

1. A single-family residence is allowed one (1) ~~nameplate~~ sign only, not to exceed five (5) feet in height or two (2) square feet in area, if it is freestanding. ~~The Said~~ sign shall not be illuminated, except by indirect lighting. No permit shall be required.
2. A single family lot which has been granted a Use Permit by City Council as provided in section 35-305 of the Chandler City Code to operate a nonresidential land use may display signage in compliance with the Residential Conversion Policy as approved by the City Council. A sign permit shall be required to ensure conformance with Use Permit approval.

B. Single family subdivisions. Subdivisions may display signs subject to the following standards:

1. Signs shall be attached to a perimeter wall or a decorative masonry wall in a landscaped setting not to exceed six (6) feet in height.

ZCA16-0002 City of Chandler / Sign Code Amendment (“redlined” version)

Draft date: April 19, 2017

2. The location of said signs shall be limited to the entrances of single family subdivisions.
3. Signs shall not be illuminated, except by indirect lighting or halo lighting.
4. Each sign shall not exceed fifty (50) square feet in area.
5. A sign permit shall be required.

C. Flags are permitted as provided for in section 39-9.12.

39-9.2 Multiple-family ~~residence~~ development.

- A. The total permanent sign area allowed, including wall signs and freestanding signs, is one (1) square foot for each dwelling unit. However, in no instance shall this total sign area exceed sixty (60) square feet, with no more than thirty-two (32) square feet fronting on any one (1) street.
- B. For other permitted buildings, the sign area permitted shall not exceed thirty-two (32) square feet.
- C. ~~Traffic directional signs are allowed on the site.~~ Signs shall not be illuminated, except by indirect lighting or halo lighting.
- D. A sign permit shall be required.
- E. Flags are permitted as provided for in section 39-9.12.

39-9.3 Mobile home parks. Signs in mobile home parks are the same as provided for multiple-family ~~residence~~ development.

39-9.4 ~~Quasi-P~~public uses, institutional uses, churches, fraternal organizations, and civic organizations.

- A. ~~For public uses, institutional uses, churches, fraternal organizations and civic organizations,~~ The total amount of permanent sign area allowed, including wall signs and freestanding signs, is thirty-six (36) square feet.
- B. ~~Temporary signs as provided in section 39-10 are permitted.~~
- C. ~~B.~~ One-half (½) of the freestanding sign area may be a change panel or digital sign.
- D. ~~C.~~ Traffic directional signs are allowed on the site. Permanent signs shall require a sign permit.
- D. Flags are permitted as provided for in section 39-9.12.

39-9.5 ~~Schools (public and parochial elementary, junior high, and senior high schools).~~

- A. ~~The amount of signage allowed for schools shall be as follows:~~
 1. ~~Wall signs. The total amount of wall signage per school shall not exceed thirty-six (36) square feet.~~
 2. ~~Freestanding signs. One (1) freestanding sign, single- or double-sided, per school, constructed in accordance with the following guidelines:~~
 - a. ~~Maximum area thirty two (32) square feet (per side).~~
 - b. ~~Maximum height fourteen (14) feet.~~
 - c. ~~Changeable copy. Changeable copy announcing school activities and functions may occupy a portion or all of the sign surface area.~~

ZCA16-0002 City of Chandler / Sign Code Amendment (“redlined” version)

Draft date: April 19, 2017

~~d. Design. The sign shall be designed to be in harmony with the architectural character (materials and colors) of the principal building(s) on the same site.~~

~~e. Illumination. Internal only.~~

~~f. Setbacks. The sign must be setback from all property lines and/or street rights-of-way a minimum distance of fifteen (15) feet.~~

~~g. Landscaping. The base of each freestanding sign shall be landscaped with a minimum of six (6) shrubs which at maturity will reach a minimum diameter of four (4) feet. Said shrubs shall be irrigated.~~

39-9.65 PCO Planned Commercial Office District.

A. Buildings developed in the PCO District shall be permitted on one (1) wall sign or one (1) freestanding sign per lot or parcel. The sign may be wall-mounted or low-profile. Said sign shall require a sign permit and shall comply with the following standards:

A1. Wall-mounted signs shall not exceed ten (10) feet above first floor elevation and shall not exceed one (1) square foot in area for each one (1) linear foot of business frontage. Said signs shall be wall- or window-mounted, on or under an architectural projection, and shall not project more than two (2) feet from the building or structure to which it is attached.

2. Freestanding Monument Signs.

a) ~~A single tenant-panel sign shall not exceed sixteen (16) square feet. Multitenantpanel signs shall be limited to four (4) square feet per tenant-panel with a combined maximum of thirty-two (32) square feet and shall contain only the name, address, and use or uses conducted within the building.~~

b) ~~Freestanding signs shall not exceed six (6) feet in height above ground level. Freestanding signs shall be of the low-profile type.~~

~~C. Directional signs shall be permitted on the site.~~

B. Flags are permitted as provided for in section 39-9.12.

C. Blade signs are permitted as provided for in section 39-9.13.

39-9.7-6 C-1 Neighborhood Commercial District.

A. Wall On-site signs shall not exceed one (1) square foot in area for each one (1) linear foot of business frontage. Said signs shall be wall- or window-mounted, on or under an architectural projection, and shall not project more than two (2) feet from the building or structure to which it is attached.

AB. Freestanding Monument Signs.

1. One (1) freestanding sign not to exceed one hundred (100) square feet in total area is allowed per single-user site.

2. ~~B. Freestanding signs for shopping centers and other multi-user sites shall conform to the standards set forth in subsection {39-9.16} of this section.~~

C. Wall and freestanding monument signs shall require a sign permit.

D. Window signs are permitted as provided for in subsection 39-9.14.

ZCA16-0002 City of Chandler / Sign Code Amendment (“redlined” version)

Draft date: April 19, 2017

E. Flags are permitted as provided for in section 39-9.12.

F. Blade signs are permitted as provided for in section 39-9.13.

~~39-9.8-7 C-2 Community Commercial District. On-site signs shall meet the following requirements in the C-2 district:~~

A. Wall Signs shall not exceed two (2) square feet in area for each linear foot of business frontage. Said signs shall be wall- or window-mounted, on or under an architectural projection. The sign shall not project more than two (2) feet from the building, or structure to which it is attached. No wall sign shall exceed two hundred (200) square feet in area.

B. Freestanding Monument Signs:

1. One (1) freestanding sign for each single-user site not to exceed one (1) square foot of sign area for each linear foot of business frontage. Where the developed parcel has an excess of three hundred (300) feet of street frontage, one (1) additional freestanding sign may be erected for each additional three hundred (300) feet of street frontage, not to exceed two (2) freestanding signs per City block. In no event will said additional signs be located closer than three hundred (300) feet to each other. The Zoning Administrator may allow a minor deviation from the three hundred (300) feet separation upon finding that such a reduction is necessary to accommodate a special circumstance that is not self-imposed by the property owner or applicant. For example, said minimum separation would not be possible due to the location of an existing utility pedestal, street scupper, or driveway and the length of the property does not provide opportunity to exceed said separation. Said reduction shall not exceed thirty (30) feet. In no instance, shall a freestanding monument sign be located closer than fifty (50) feet from the property line of a residential development.
2. ~~C.~~ Freestanding signs for shopping centers and other multi-user sites shall conform to the standards set forth in subsection ~~(39-9.16), of this section.~~
3. ~~D.~~ In no event shall the total combined area of all freestanding signs exceed four hundred (400) square feet for each developed parcel.

~~E.C.~~ Wall and freestanding monument signs shall require a sign permit. Traffic directional signs are permitted, provided they are no higher than three (3) feet. The sign may be internally illuminated or nonilluminated.

D. Window signs are permitted as provided for in subsection 39-9.14.

E. Flags are permitted as provided for in section 39-9.12.

F. Blade signs are permitted as provided for in section 39-9.13.

~~39-9.9-8 C-3 Highway Regional Commercial District. Signs shall meet the following requirements in the C-3 District:~~

A. ~~On-site~~Wall signs shall not exceed two (2) square feet in any area for each linear foot of business frontage. Said signs shall be wall- or window-mounted, on or under an architectural projection. The sign shall not project more than two (2) feet from the building, or structure to which it is attached. No wall sign shall exceed two hundred fifty (250) square feet in area.

B. Freestanding Monument Signs:

1. One (1) ~~detached~~freestanding sign for each developed area or parcel not to exceed one and one-half (1½) square feet of sign area for each linear foot of business frontage. Where the developed parcel under single ownership has an excess of three hundred (300) feet of street frontage, one (1) additional detached bonus sign may be erected for each additional

ZCA16-0002 City of Chandler / Sign Code Amendment (“redlined” version)

Draft date: April 19, 2017

~~three hundred (300) feet of street frontage, not to exceed two (2) detached signs per City block. In no event will bonus signs be located closer than three hundred (300) feet to each other. The Zoning Administrator may allow a minor deviation from the three hundred (300) feet separation upon finding that such a reduction is necessary to accommodate a special circumstance that is not self-imposed by the property owner or applicant. For example, said minimum separation would not be possible due to the location of an existing utility pedestal, street scupper, or driveway and the length of the property does not provide opportunity to exceed said separation. Said reduction shall not exceed thirty (30) feet. In no instance, shall a freestanding monument sign be located closer than fifty (50) feet from the property line of a residential development.~~

- ~~2. C. Detached~~Freestanding signing for shopping centers and other multi-user sites shall conform to the standards set forth in subsection 39-9.16. ~~of this section 39-9.~~
- ~~3. D. In no event shall the total combined area of all detached~~ freestanding signs exceed four hundred fifty (450) square feet.

C. Wall and freestanding monument signs shall require a sign permit.

D. Window signs are permitted as provided for in subsection 39-9.14.

E. Flags as are permitted provided for in section 39-9.12.

F. Blade signs are permitted as provided for in section 39-9.13.

~~E. Traffic directional signs are permitted, provided they are no higher than three (3) feet. The sign may be internally illuminated or nonilluminated. Traffic directional signs are subject to approval of the City Traffic Engineer and not included in area calculations.~~

~~F. Billboards are permitted along Chandler Boulevard and Arizona Avenue. Such signs are permitted only by a use permit and subject to the following:~~

- ~~1. Outdoor advertising signs may be internally illuminated, indirectly illuminated, or directly illuminated.~~
- ~~2. No such sign structure shall be erected in any block in which fifty (50) percent or more of the lots in that block are being used for a residential purpose. If a sign is erected on a corner lot, that sign shall be considered to be in the block along the street to which the sign is oriented.~~
- ~~3. No part of a sign structure shall be erected closer than six (6) feet to a future street right-of-way or the front setback of a building which is within one hundred (100) feet whichever is the greater; however, when a sign is erected between two (2) buildings which are within one hundred (100) feet of the sign, the sign shall not be erected closer to that street than a line drawn from the nearest front corner of each building. When a sign is erected within three (3) feet of a building, only that building setback need be maintained.~~
- ~~4. Such sign structure must maintain a side yard setback from any adjacent residential zoning district or residential use equal to that of the residential zoning district or half the sign's structure height, whichever is greater.~~
- ~~5. No such sign structure may be closer than one thousand (1,000) feet to any other such sign structure on the same side of the same street and oriented to that street unless said structures are back-to-back, or V-shaped. No such sign shall be closer than eight (8) feet to ground level or forty-five (45) feet in height. For purposes of this section, a sign structure may be back-to-back, or V-shaped.~~
- ~~6. No such sign structure face area or combination of sign structure face areas shall exceed three hundred twenty (320) square feet unless double-faced or V-shape.~~

ZCA16-0002 City of Chandler / Sign Code Amendment (“redlined” version)

Draft date: April 19, 2017

~~7. Embellishments shall not extend more than five and one-half (5½) feet above or below the horizontal edges of the sign structure face area and not more than three (3) feet beyond any vertical edge of the sign structure face area. Neonized embellishments shall conform to the requirements of the Electrical Code of the City. The total area of all such embellishments shall not increase the total area of the outdoor advertising structure face area to which they are attached by more than twenty (20) percent.~~

~~8. On any lot contiguous to a residential zoning district or separated therefrom only by an alley, no such illuminated sign structure may be placed within one hundred (100) feet of said residential zoning district in such a manner that any portion of the face of the sign is visible to the adjacent residential district.~~

~~9. Outdoor advertising signs shall not be erected or painted upon the roof or wall of any building, nor shall any such sign be partially or totally supported by the roof or roof structure of any building.~~

~~10. No sign permit shall be issued for outdoor advertising signs (billboards) until two (2) copies of a site development plan and two (2) copies of a landscape plan have been submitted and approved. Said plans shall be in accordance with the provisions of the Zoning Code.~~

~~11. Any variance or exception to the foregoing shall be in accordance with the provisions of the Zoning Code.~~

~~39-9.10-9~~ Industrial zones. In all industrial zones, permitted signs shall be in accordance with provisions in the C-3 District.

~~39-9.11~~ AG-1 Agricultural District. ~~In AG-1 Districts:~~

A. One (1) ~~identification~~ freestanding monument sign is permitted. It shall not exceed twenty-four (24) square feet in area.

~~B. Billboards are permitted in accordance with the provisions set forth in the C-3 zone.~~

~~39-9.12-11~~ Planned Area Development designations. For such properties zoned with a planned area development (PAD) designation, all signing shall be subject to the standards specified for the C-3 zoning district unless otherwise governed by sign criteria specified either as part of a Preliminary Development Plan approval by the Planning and Zoning Commission and City Council, or other previous sign package approval by the City.

39-9.12 Flags. Flag poles and flags shall comply with the following standards:

- A. No more than three (3) flag poles shall be installed on each single family residential lot, multifamily development, model home cluster, shopping center, or other multiuser site. Said flag poles may be wall-mounted or permanently installed in the ground.
- B. Permanently installed in-ground flag poles shall require permit approval to ensure they are structurally sound and comply with the standards provided herein. A permit shall not be required for wall-mounted flag poles. A separate permit shall not be required to display flags.
- C. The minimum setback for permanently installed in-ground flag poles shall equal one-half (1/2) the setback required for a principal building as set forth by the zoning district in which it is located.
- D. Flag pole height.
 - 1. Permanently installed in-ground flag poles and wall-mounted flag poles in single family residential districts shall not exceed twenty five (25) feet in height, or shall not be higher than the highest point of the principal building's roof, whichever is lower.

ZCA16-0002 City of Chandler / Sign Code Amendment (“redlined” version)

Draft date: April 19, 2017

2. Permanently installed in-ground flag poles and wall-mounted flag poles in multiple family districts and model home clusters shall not exceed fifty (50) feet in height or shall not be higher than the highest point of the nearest principal building’s roof on the premises, whichever is lower.
 3. Permanently installed in-ground flag poles and wall-mounted flag poles in nonresidential districts shall not exceed one hundred (100) feet in height or shall not be higher than the highest point of the nearest principal building’s roof on the premises, whichever is lower.
- E. In any district, the length of each flag, which is the longer side of a flag that is perpendicular to the flag pole, shall not exceed one third (1/3) of the maximum height allowed for in-ground flag poles.

~~39-9.13~~ Shingle-Blade signs. ~~Shingle-Blade signs are may be used to identify by businesses whose front entrance is under a roof overhang which extends over a public right-of-way. These signs are included as part of permitted the total allowed sign area.~~

- A. Only one (1) sign shall be allowed for each business front, and a sign permit is required for such sign.
- B. The sign may be a projecting blade sign attached to the front wall of the building or a hanging blade sign hanging from the roof overhang or colonnade, which is located next to the business entrance.
- C. The sign must be perpendicular to the building front and shall contain not exceed more than four (4) square feet in area.
- ~~C~~D. The minimum clearance of the sign shall be a minimum of eight (8) seven (7) feet above the sidewalk in accordance with subsection 39-7.9(B)3.
- ~~D~~E. No part of the sign shall project beyond the overhang of the roof or any corner of the building.
- ~~E.~~ The shingle sign shall contain the name of the business only.

~~39-9.14~~ Window signs. Window signs may be painted on or otherwise displayed from the surface of any window, showcase or other similar facility. The area of such signs shall not exceed twenty-five (25) percent of each contiguous window the area. of the window on which it is displayed. The area of said sign shall not be included in the total allowed sign area.

~~39-9.15~~ Digital signs. Digital signs shall comply with the following criteria:

- A. Automatic dimming capability: All digital signs shall be equipped with a fully operational light sensor or other device that automatically adjusts the intensity of the sign according to ambient light conditions.
- B. Measurement criteria: Ambient light conditions shall be measured with the digital sign off. The illuminance of a digital sign shall be measured while it is displaying a white image for a full color-capable digital sign, or a solid color for a single-color digital sign. All measurements shall be taken as close as practical to be perpendicular to the sign at a distance determined by the Zoning Administrator.
- C. Illumination limit. The difference between the foregoing off (ambient light) and the full digital sign display measurements shall not exceed 0.3 footcandles at night.
- D. Manual control. Digital signs shall be designed with the capability of freezing the display in one static position, displaying a full black screen, or turning the sign off in the event of a malfunction.
- E. Required permits: All digital signs shall require a sign permit and electrical permit.

ZCA16-0002 City of Chandler / Sign Code Amendment (“redlined” version)

Draft date: April 19, 2017

~~Design. All signs shall be fully integrated with the design of the building and the site development, reflecting the architecture, building materials, and landscape elements of the project.~~

~~A. The means of integrating freestanding signs with the architecture of the building shall be achieved through replication of architectural embellishments, colors, building materials, texture, and other elements found in the building design. As an example, a canister sign mounted atop a masonry base or other fixture shall not be considered as integrated with the architecture of the building. Instead, where a canister sign is proposed as a component of a freestanding sign, such canister shall be bordered or backgrounded by the architectural materials and embellishments found within the building design.~~

~~B. Integration shall also include the use of sign graphics that are consistent in terms of lettering style, color, and method of attachment as used for wall-mounted signing found on the building.~~

~~C. When mounted on a building, the sign shall be located on or below the fascia or parapet wall of the primary building; when freestanding, the sign shall not exceed six (6) feet in height except as provided in subsection (16) of this section. All freestanding signs shall be placed in conformance with Standard Detail No. 39, Sight Distance Standard, as adopted by the City and administered by the City Engineer, so as not to impede traffic visibility at street corners and driveways.~~

39-9.16 Signs for shopping centers and other multiuser sites.

A. Sign criteria shall be established as part of a Preliminary Development Plan (PDP) or building/sign plan review process. A sign permit shall be required for any of the signs provided for herein.

B. ~~Wall-mounted identification~~Wall signs for shopping centers and other commercial and industrial sites shall be subject to the development standards as specified in this chapter for the particular district in which the property is zoned. Cabinet signs, ~~other than corporate logos,~~ shall not exceed twenty five (25) percent of the installed sign area. ~~be prohibited~~ Signs shall be integrated with building façades and shall be proportional to the scale of the façades so that they are not the dominant architectural features.

C. Freestanding ~~monument identification~~ signs for shopping centers and other multitenant commercial centers (individually, collectively, "centers") and for industrial sites shall be subject to the following standards:

1. One (1) ~~freestanding detached identification~~ sign per arterial street, not to exceed one (1) square foot of sign face area for each linear foot of business frontage. ~~Where the property has an excess of three hundred (300) feet of frontage along an arterial street, One (1) additional sign may be erected for each additional three hundred (300) feet of frontage along an arterial street.~~ along such frontage, not to exceed two (2) signs per frontage and located not Said signs shall not be less than three hundred (300) feet apart, except that the Zoning Administrator may allow a minor deviation from said separation upon finding that such a reduction is necessary to accommodate a special circumstance that is not self-imposed by the property owner or applicant. For example, said minimum separation would not be possible due to the location of an existing utility pedestal, street scupper, or driveway and the length of the property does not provide opportunity to exceed said separation. Said reduction shall not exceed thirty (30) feet. In no instance, shall a freestanding monument sign be located closer than fifty (50) feet from the property line of a residential development.

2. Maximum sign height shall not exceed six (6) feet, except as provided below:

(a) A center, but not an industrial site, located at the corner of two (2) major arterials may have no more than one (1) sign with a maximum height of fourteen (14) feet.

(b) A center, but not an industrial site, at all other locations except the corner of two (2) major arterials may have no more than one (1) sign with a maximum height of ten (10) feet.

ZCA16-0002 City of Chandler / Sign Code Amendment (“redlined” version)

Draft date: April 19, 2017

(c) All other signs at a center, but not an industrial site, may be increased to a maximum height of eight (8) feet provided that they are enhanced with a higher level of design as provided for in subsection 39-9.16(C)3 below.

(d) Notwithstanding subsections (a), (b) and (c) above, in no instance shall any sign located at the street corner of a center, or located less than one hundred fifty (150) feet from the street corner along either frontage, exceed a maximum height of eight (8) feet.

(e) Notwithstanding subsections (a), (b), (c) and (d) above, signs located within one hundred (100) feet from the property line of a residential development ~~service station price signs~~ shall not exceed six (6) feet in height.

3. Each ~~identification freestanding sign~~ as permitted herein shall feature no more than ~~two (2) occupant names~~ three (3) panels, ~~irrespective of an occupancy being a major or minor tenant within the center, and whether located as part of the main building complex or as an independent building pad.~~ Notwithstanding the foregoing, ~~identification signs~~ enhanced with a higher level of design may be eligible for an additional two (2) ~~occupant names~~ panels for a total of no more than ~~four (4) occupant names~~ five (5) panels per ~~freestanding identification~~ sign. Higher levels of design may include but not be limited to:

- a) ~~Increasing architectural integration with buildings in the center.~~
- b) ~~Adding tenant panel names with~~ Utilizing individual three-dimensional letters or other three-dimensional sign components.
- c) ~~Enhancing landscaped setting around the sign.~~
- d) ~~Upgrading quality materials.~~
- e) ~~Eliminating cabinet panels.~~

~~One (1) or more of the permitted identification signs may also include, or feature exclusively, any generic name as may be chosen for the center; however, each sign need not identify the same occupant name(s). In addition, any identification sign located at the street corner of the site, featuring only the generic name of the center and not a tenant name, may be exempted from the maximum number of signs allowed along the street frontage.~~

4. ~~Signage on gas canopies shall be limited to users (oil company) logo sign only. Notwithstanding subsection 39-9.16(C)1, a center may erect one additional freestanding monument sign at the street corner, and/or main entrance(s) of the site subject to the following standards:~~

- a) One (1) freestanding sign shall be allowed for each property unless it is a corner lot, in which case one (1) sign shall be allowed per street front.
- b) Said sign(s) shall be excluded from the total number of freestanding signs allowed in subsection 39-9.16(C)1.
- c) Said freestanding sign(s) shall be in the form of a decorative wall placed in a landscaped setting.
- d) The height of said sign shall not exceed six (6) feet from ground level.
- e) Said sign(s) shall not contain any panels as provided for in subsection 39-9.16(C)3.
- f) The maximum sign area for each additional freestanding sign shall not exceed thirty two (32) square feet.

ZCA16-0002 City of Chandler / Sign Code Amendment (“redlined” version)

Draft date: April 19, 2017

5. Notwithstanding subsection 39-9.16(C)3, a center may add one (1) additional sign to each freestanding monument sign permitted therein. Said sign shall not be a panel, shall be proportional to the size of the freestanding monument sign on which it is located, and shall be excluded from the total allowable sign area therein.

D. *Additional quality standards.* The intent of the following standards is to encourage creative and innovative design techniques, quality and merit. A minimum of three (3) of the following items shall be achieved for shopping centers, office and commercial complexes:

1. Incorporate site signage on low planter walls in lieu of freestanding monument signs to create a shared identity for the site.
2. Utilize letters and other sign components that are "halo" or indirectly illuminated throughout the entire site.
3. Utilize individual reverse pan channel letters throughout the entire site.
4. Letter size shall be limited to fifteen (15) percent of the building height for all wall-mounted signs.
5. Incorporate landscape planter feature at base of all freestanding monument signs.
6. ~~Corporate logos~~Cabinet signs shall be limited to ten (10) percent of the total allowable sign area~~size~~.
7. Any other design amenity, which is otherwise not required but which meets the general intent for design innovation, may be substituted for any of the above additional quality standards.

~~39-9.17 Reserved. Bus shelter signing. Notwithstanding the provisions of section 39-7.10 of this chapter regarding signs in the public right-of-way, signing in conjunction with bus shelter facilities as approved by the City of Chandler and other governmental agencies shall be permitted. Development standards, including but not limited to sign face area, height, location, etc., shall be determined in accordance with all bus shelter design requirements as specified by the City Engineer, in coordination with the governmental agencies as appropriate.~~

39-9.18 CCD—City Center District.

A. *General requirements.*

- ~~1. No sign shall be permitted which does not correctly identify the occupancy, services, or types of products offered, within the business premises.~~
- ~~2. All signs shall be free of labels and manufacturer's advertising except as specified in chapter 39, section 39-7.12 of this Code.~~
1. ~~3.~~For those installations involving paint applied to a sign board, all copy and borders shall be applied with a high quality acrylic latex and primer, in accordance with manufacturer's recommendations.
2. ~~4.~~Only business identification signage which is surface-mounted may be permitted on the side or rear elevation of a building, provided however, that such elevation is improved in an architectural manner similar to the front elevation of the building. The design of such signage shall comply with the standards and requirements for surface-mounted signs above the colonnade as set forth herein in chapter 39, section 39-9.18. B.1 of this Code.
- ~~35.~~ All signage materials, including sign boards and letter styles, shall to the extent possible, replicate the historic look of signage consistent with the Early Twentieth Century commercial architecture of buildings within the City Center District (CCD), as described in Chapter 35,

ZCA16-0002 City of Chandler / Sign Code Amendment (“redlined” version)

Draft date: April 19, 2017

section 3204(h) of this Code, or enhance said historic qualities in a manner that further improves the quality of the downtown environment.

4. ~~6.~~—All surface-mounted signage, whether above or below the colonnade, shall be manufactured as individual letters, or be manufactured as a sign board which may then be mounted onto the building wall surface. No signage shall be painted directly onto the exterior wall surface of any building above or below the colonnade, except for window graphics.
5. ~~7.~~—Surface-mounted signage above the colonnade shall be the only type of signage permissible for internal illumination by the business owner or building owner. Indirect lighting for surface-mounted signage above or below the colonnade, wherein such lighting is not provided by the City, shall be prohibited.
6. ~~8.~~—Raceways may be used for the purpose of electrifying individual letters constituting a surface-mounted sign above the colonnade. If used, such raceway shall be mounted behind the letters only, and painted to match the building.
7. ~~9.~~—Sign copy and borders may be any color; background colors shall either match, or otherwise complement, the building color. If used, sign borders shall be a maximum four (4) inch width.
- ~~10. A corporate logo for the business occupant only, may be permitted for any sign type, provided however, such logo does not occupy more than twenty-five (25) percent of the maximum allowable sign face area.~~
8. ~~44.~~—As provided herein, sign boards shall either be: two (2) inch thick solid redwood sandblasted to a depth of three-eighths (3/8) inch to one-half (1/2) inch, or a manufactured facsimile thereof; or other fabrication of metal or other materials that achieve a two (2) inch thickness and provides exterior durability.
9. ~~42.~~—As provided herein, the use of neon as a means of illumination, whether internal or external to a sign face, shall be permitted at the rate not to exceed one (1) such sign above the colonnade per business occupant.
10. ~~43.~~—Any sign installation for which a City of Chandler building permit was issued prior to the effective date of these regulations, which subsequently becomes non-conforming to these regulations as defined in this Chapter 39, section 39-3 of this Code, may continue in existence in the manner provided for in ~~chapter 35, section 39-5 of this Code~~.
11. ~~44.~~—For any sign proposed to overhang any portion of the public right-of-way, a separate building permit shall be required in accordance with the standards and requirements of the ~~Uniform Building Code~~ as adopted by the City of Chandler, and an encroachment permit shall be required in accordance with Chapter 46 of the Chandler City Code.
12. ~~45.~~—All signs shall be maintained in a "like new" condition.

B. *Design requirements.* All or any combination of the following sign types may be permitted for each business use, in conformance with the standards and requirements set forth herein.

1. *Surface-mounted signage above the colonnade:*
 - a) For signs comprising one (1) line of copy, no letter or logo shall exceed twenty-four (24) inches in height; for signs comprising the maximum allowable two (2) lines of copy, the combined height of both lines of copy together with the space between lines, shall not exceed thirty-six (36) inches of height. Length of said signs shall not exceed eighty (80) percent of the storefront width.

ZCA16-0002 City of Chandler / Sign Code Amendment (“redlined” version)

Draft date: April 19, 2017

b) Signs may be mounted flush, angled, bowed, or perpendicular to the wall surface, and where possible, be centered horizontally over the storefront. Irrespective of the method used for mounting, no sign shall extend above the top of the wall parapet, nor be mounted on any roof or roof fascia. No sign shall extend more than four (4) feet from the exterior face of the building wall, and no sign shall overlap any window, door, or architectural feature. Maximum sign face area for any sign mounted perpendicular to the exterior face of the building wall shall be twenty-four (24) square feet.

c) Signs may be illuminated by internal sources, including reverse pan channel techniques. Any use of neon lighting, mounted to the exterior surface of letters or logo, shall be single tube only. In no event shall any flashing, blinking, rotating, or light motion implying movement be permitted.

~~d. Signs shall be limited to business identification name and logo only; services, products, and business slogans shall be prohibited.~~

~~D~~e~~~~ No more than one (1) sign per business occupant shall be permitted.

e. A sign permit shall be required.

2. *Surface-mounted signs below the colonnade:*

a) Signs may be mounted flush, angled, bowed, or perpendicular to the wall surface, and where possible, be centered horizontally within the storefront. No sign shall extend more than four (4) feet from the exterior face of the building wall, with not less than ~~nine-seven~~ (97) feet vertical clearance measured from the bottom of the sign face to the finished sidewalk grade.

b) Maximum sign face area for a flush mounted sign shall be determined by the extent of continuous flat wall surface while maintaining a minimum two (2) inch distance from any door trim, window trim, wall pop-out, or other architectural feature that constitutes a change in exterior wall plane. Maximum sign face area for any sign mounted perpendicular from the exterior face of the building wall shall be seven (7) square feet.

c) No sign shall overlap any door, window, or architectural feature, nor shall any signage be placed above any window(s).

~~d. Signs shall be limited to business identification name and logo only; services, products and business slogans shall be prohibited.~~

~~D~~e~~~~ The maximum number of signs permitted shall not exceed the ratio of one (1) sign per twenty (20) feet of storefront or portion thereof.

e) A sign permit shall be required.

3. *Colonnade hanging blade signs.*

a) If used, a colonnade hanging blade sign shall be a sign board centered between, and in the same plane as, the columns of the colonnade, with a minimum of two (2) feet six (6) inches horizontal clearance from any column, and a minimum ~~nine-seven~~ (97) feet vertical clearance from the finished sidewalk grade.

b) Maximum sign face area shall not exceed sixteen (16) square feet.

~~c. Signs shall be limited to business identification name and logo only; services, products, and business slogans shall be prohibited.~~

ZCA16-0002 City of Chandler / Sign Code Amendment (“redlined” version)

Draft date: April 19, 2017

c) Not more than one (1) colonnade hanging blade sign per business occupant shall be permitted.

d) Colonnade hanging blade signs shall not be illuminated by any means beyond that which is provided by the City.

ef) Except for temporary signs as otherwise permitted in accordance with chapter 39, section 39-10 of this Code, no sign other than a colonnade hanging blade sign installed in the manner specified in this subsection, shall be hung or attached to the colonnade.

f) A sign permit shall be required.

4. *Window and door signs.*

a) Maximum sign face area, as measured by an enclosed rectangular perimeter around the sign, shall not exceed twenty-five (25) percent of the window or door surface, excluding transoms.

b) Signs may be painted on, adhered to, or suspended behind the glass door or window surface. No sign(s) shall be placed on, or mounted in front of, any transom window(s).

c) Signs may be illuminated by the tenant inside the glass door or window, including the use of neon; provided, however, that neon shall not be used to outline any window.

d) A window or door sign shall not require a sign permit. Signs permitted may include business identification, including logo and hours of business, as well as the products and services offered therein. Neon may only be used for the business name, logo, and an "open/closed" sign; the use of neon for identifying products and services, hours of operation, business slogans, and other elements shall be prohibited.

5. Banners placed above the colonnade, for any purpose, shall ~~be permitted~~ require a temporary sign permit and shall be allowed for a maximum period of thirty (30) cumulative days within each six (6) month period in a calendar.

39-10. - Temporary signs.

39-10.1 Purpose. The City of Chandler finds that the proliferation of temporary signs is a distraction to the traveling public and creates aesthetic blight and visual clutter that threatens the public's health, safety and welfare. The City also recognizes a legitimate need for temporary signs for a wide variety of functions or special occasions. The purpose of these regulations is to allow temporary signs in such a manner that limits the distractions to the traveling public and eliminates or reduces aesthetic blight and visual clutter caused by temporary signs.

39-10.2 General regulations for all temporary signs.

- A. Temporary signs shall be allowed only in compliance with the provisions of this section.
- B. Temporary signs shall not be attached to any public facility such as government signs and supporting poles, utility poles, street lights, light poles, and trees on public property.
- C. Temporary signs shall not obstruct view or paths in a manner that creates a hazard for pedestrian or vehicular traffic.
- D. Temporary signs shall be of sufficient weight, made of durable material and be properly secured to withstand wind gusts, storms and other natural elements.
- E. No temporary signs shall be mounted on a building roof.

ZCA16-0002 City of Chandler / Sign Code Amendment (“redlined” version)

Draft date: April 19, 2017

- F. No temporary signs shall emit sound or odor, except for seasonal decorations.
- G. No temporary signs shall have animated or moving parts, except for seasonal decorations and air-activated signs as provided for in section 39-10.3(B).
- H. No temporary signs shall imitate traffic control signs, or obscure actual municipal or other public traffic control signs or devices.
- I. No temporary signs shall be placed upon private property without the property owner’s approval.
- J. No temporary signs located in single family residential zones shall be illuminated, except for seasonal decorations.
- K. Search lights, strobe lights, intermittent or flashing illumination, holographic projections, laser light displays, beacons and other similar temporary signs or effects shall be prohibited.
- L. The Zoning Administrator may remove or cause to be removed any temporary sign erected, displayed upon, or projecting into public property that is not expressly allowed by this section or protected by state statute, or which presents a critical safety hazard requiring immediate action.
- M. Exceptions to general regulations for all temporary signs provided herein and specific temporary sign types as provided for in section 39-10.3 may be permitted when approved as part of a City sponsored public event or special event permit as provided for in Chapter 32 of the Chandler City Code.

39-10.3 Regulations for specific temporary sign types.

- A. A-Frame or T-Frame signs.
 - 1. Area and Height: The area of any single sign shall not exceed twelve (12) square feet in area nor exceed four (4) feet in height.
 - 2. Location, number of signs and duration:
 - a) Each business or nonresidential use located in a commercial or industrial district may place one (1) sign within the building envelope and shall maintain a minimum five (5) foot clearance to allow unobstructed pedestrian use of the privately owned pedestrian pathway located therein. Said sign shall be displayed only during business hours. Notwithstanding the foregoing, an unlimited number of signs may be displayed when said signs are located within a permitted outside display area.
 - b) Each business or nonresidential use which occupies a building that fronts onto and abuts the edge of the public right-of-way may place one (1) sign on the public sidewalk within the building envelope. The placement of said sign shall maintain a minimum five (5) foot clearance to allow unobstructed pedestrian use of the public sidewalk. Said sign shall be displayed only during business hours.
 - c) Each single family lot or model home may place one (1) sign anywhere on the property, and each single family lot or model home cluster may place one (1) additional sign at each turning movement beginning at the subject property and extending for a maximum of one (1) mile distance from said property up to a maximum of ten (10) signs. Said signs shall be placed away from the street and no closer than five (5) feet from the curb behind the public sidewalk or no closer than five (5) feet from the edge of pavement when there is no public sidewalk. Said signs shall be displayed only on days when the property is open to the public (e.g. garage/yard sale, open house, and model home business hours).

ZCA16-0002 City of Chandler / Sign Code Amendment (“redlined” version)

Draft date: April 19, 2017

- d) Each multiple family development, mobile home park, or mobile home subdivision may place one (1) sign within the building envelope of the building containing the office. Said sign shall maintain a minimum five (5) foot clearance to allow unobstructed pedestrian use of the privately owned pedestrian path located therein. Said sign shall be displayed only during office hours.
 - e) Each quasi-public or institutional use not located in a commercial or industrial district may place one (1) sign within the building envelope and shall maintain a minimum five (5) foot clearance to allow unobstructed pedestrian use of the privately owned pedestrian pathway located therein. One (1) additional sign may be placed at each turning movement beginning at the property and extending for a maximum of one (1) mile distance from said property up to a maximum of ten (10) signs. Said signs shall be placed away from the street and no closer than five (5) feet from the curb behind the public sidewalk or no closer than five (5) feet from the edge of pavement when there is no public sidewalk. Said signs shall be displayed only when said property is open to the public.
3. Approval process: No sign permit shall be required.
- B. Air-activated signs.
1. Area and Height: Signs shall not exceed fourteen (14) feet in height.
 2. Location:
 - a) Signs shall be set back a minimum of five (5) feet from the public right-of-way or a distance that is equal to the height of the sign, whichever is greater.
 - b) Air-activated signs shall only be allowed on nonresidential properties, except for seasonal decorations on residential properties, which do not require a permit.
 3. Number of signs: No more than two (2) air-activated signs may be displayed concurrently. For the purpose of calculating the number of signs, segments of multiple pennants hung on the same premises shall collectively be considered one (1) sign and segments of streamers hung on the same premises shall collectively be considered one (1) sign.
 4. Duration: Each business or nonresidential use shall be allotted no more than thirty (30) cumulative days within each six (6) month period in a calendar year to display air-activated signs, banners, or feather signs. One (1) day shall be counted as being exhausted from the total allotment for each day that one or any combination of the aforementioned signs is displayed.
 5. Approval process: A temporary sign permit shall be required to display any air-activated sign, except common party balloons shall not require a permit when they do not exceed a height of fourteen (14) feet from finished grade.
 6. Other requirements:
 - a) Signs shall be fastened to the ground or a structure so that it cannot shift more than three (3) feet horizontally under any condition.
 - b) Signs shall require compliance with applicable building codes.
- C. Banners.
1. Area and Height:

ZCA16-0002 City of Chandler / Sign Code Amendment (“redlined” version)

Draft date: April 19, 2017

- a) Banners shall not exceed the square footage of installed and/or permitted wall signs as provided for in section 39-9.
 - b) Notwithstanding the foregoing, each vertical banner shall not exceed twelve (12) square feet in area.
 - c) Banners attached to buildings and vertical banners affixed to a structure located within a permitted outside display area shall not project above the roof line or exceed a height of twenty five (25) feet from finished grade to the top of the banner, whichever is lower. Said banners shall maintain a minimum clearance of seven (7) feet above finished grade when placed upon an area open for common or general use of the public.
 - d) Detached banners shall not exceed a height of eight (8) feet.
2. Location:
- a) Banners shall not be attached to single family homes.
 - b) Detached banners shall be setback a minimum of five (5) feet from the public right-of-way and driveways.
 - c) Vertical banners shall only be displayed in permitted outside display areas
3. Number of signs: Each business or nonresidential use may display no more than one (1) banner, which may be attached to a building or detached. Notwithstanding the foregoing, an unlimited number of vertical banners may be displayed when affixed to structures that are located within a permitted outside display area.
4. Duration: Each business or nonresidential use shall be allotted no more than thirty (30) cumulative days within each six (6) month period in a calendar year to display air-activated signs, banners, or feather signs. One (1) day shall be counted as being exhausted from the total allotment for each day that one or any combination of the aforementioned signs is displayed, except that the display of vertical banners located in permitted outside display areas and banners that do not exceed sixteen (16) square feet in area which are displayed during construction of the site or during a City funded or designated construction project that is located adjacent to the business or nonresidential use erecting said sign shall not be counted toward said allotment.
5. Approval process: A temporary sign permit shall be required to display banners as provided herein, except no permit shall be required for:
- a) Vertical banners; and
 - b) Banners that do not exceed sixteen (16) square feet in area which are displayed during construction of the site or during a City funded or designated construction project that is located adjacent to the business or nonresidential use erecting said sign, and which is promptly removed after construction is completed.
6. Other requirements:
- a) Detached banners shall be secured to a freestanding temporary support structure, uprights, stakes or poles that are sufficiently anchored to withstand wind pressure.
 - b) Banners shall not be tethered to or otherwise affixed to trees or any other landscaping.
 - d) Any banner that is partially torn, loose or otherwise unsecured shall be deemed unsafe and shall be immediately replaced, refastened, removed or replaced.

ZCA16-0002 City of Chandler / Sign Code Amendment (“redlined” version)

Draft date: April 19, 2017

- e) Banners shall not be affixed to or displayed over a freestanding monument sign.

D. Feather signs.

1. Area and Height: Feather signs shall not exceed twelve (12) square feet in area and shall not exceed eight (8) feet in height from grade.
2. Location: Feather signs shall only be allowed in multiple family districts and nonresidential properties, and shall be setback a minimum of five (5) feet from the public right-of-way or a driveway. Said signs shall not be placed closer than twenty (20) feet to another feather sign or freestanding monument sign.
3. Number of signs: Each business, multiple family development or other nonresidential use may display no more than two (2) feather signs.
4. Duration: Each business, multiple family development or other nonresidential use shall be allotted no more than thirty (30) cumulative days within each six (6) month period in a calendar year to display air-activated signs, banners, or feather signs. One (1) day shall be counted as being exhausted from the total allotment for each day that one or any combination of the aforementioned signs is displayed.
5. Approval process: A temporary sign permit shall be required to display feather signs as provided herein.
6. Other requirements:
 - a) Feather signs shall be securely attached to mounting poles which are secured to the ground.

E. Large temporary freestanding signs (17 – 160 square feet):

1. Number of signs:
 - a) Each nonresidential development or center that is greater than two (2) acres and each property that is currently undeveloped, used for agriculture or under construction may display one (1) large temporary freestanding sign per street frontage. Parcels with an excess of three (300) hundred feet of street frontage may display one (1) additional large temporary freestanding sign per three hundred (300) feet of street frontage. Said signs shall not be less than three hundred (300) linear feet apart, except signs posted on different parcels may be less than three (300) linear feet apart from each other. The Zoning Administrator may allow a minor reduction from said separation of signs displayed on the same parcel upon finding that such a reduction is necessary to accommodate a special circumstance that is not self-imposed by the property owner or applicant. For example, said minimum separation would not be possible due to the location of an existing utility pedestal, street scupper, or driveway and the length of the property does not provide opportunity to exceed said separation. Said reduction shall not exceed thirty (30) feet.
 - b) Notwithstanding the foregoing, signs or notices required or posted by a government agency shall not be counted towards the number of signs permitted herein.
2. Area, height, location and materials:
 - a) The sign face of signs displayed on properties that are currently undeveloped, used for agriculture or under construction shall not exceed thirty two (32) square feet in area for the first acre or portion thereof. When the subject property exceeds one (1) acre in size, the sign area may be increased four (4) square feet for each additional acre or portion thereof not to exceed one hundred sixty (160) square feet.

ZCA16-0002 City of Chandler / Sign Code Amendment (“redlined” version)

Draft date: April 19, 2017

- b) The sign face of signs displayed on nonresidential developments or centers containing less than ten (10) acres but more than two (2) acres shall not to exceed thirty-two (32) square feet.
 - c) The sign face of signs displayed on nonresidential developments or centers containing ten (10) acres or more are shall not exceed fifty (50) square feet and may be illuminated. Such illumination shall be indirect lighting only.
 - d) Said signs shall not exceed fifteen (15) feet in height.
 - e) Said signs shall not be placed closer than fifteen (15) feet to a public right-of-way.
 - f) All signs shall be made of a rigid and durable material that will withstand the elements.
3. Approval process and duration: Signs exceeding thirty two (32) square feet in area or eight (8) feet in height shall require a sign permit in order to ensure the structural safety of said signs. Said permit shall be valid for two (2) years and shall be renewable on an annual basis thereafter.
- F. Midsize temporary freestanding signs (7 – 16 square feet):
- 1. Number of signs:
 - a) Each parcel may display one (1) midsize temporary freestanding sign per street frontage. Parcels with an excess of three hundred (300) feet of street frontage may display one (1) additional midsize temporary freestanding sign for each additional three hundred (300) feet of street frontage. Said signs shall not be less than three hundred (300) linear feet apart, except signs posted on different parcels may be less than three hundred (300) linear feet apart from each other. The Zoning Administrator may allow a minor reduction from said separation of signs displayed on the same parcel upon finding that such a reduction is necessary to accommodate a special circumstance that is not self-imposed by the property owner or applicant. For example, said minimum separation would not be possible due to the location of an existing utility pedestal, street scupper, or driveway and the length of the property does not provide opportunity to exceed said separation. Said reduction shall not exceed thirty (30) feet.
 - b) Notwithstanding the foregoing, an unlimited number of the following signs may be displayed, which shall not be counted towards the number of signs permitted herein:
 - i. Signs or notices required or posted by government.
 - ii. Signs leading to or displayed within a model home cluster which are not visible from an arterial or collector street.
 - 2. Area, height, location and materials:
 - a) The sign face of said signs shall not exceed sixteen (16) square feet in area.
 - b) Signs displayed on nonresidential developments shall not exceed a height of twelve (12) feet.
 - c) Signs displayed on residential properties shall not exceed a height of six (6) feet.
 - d) The sign post shall not be closer than ten (10) feet to the curb or edge of pavement where there is no curb. The sign face may encroach no more than two (2) feet into said ten (10) feet setback.
 - e) In no event shall the sign face encroach or extend over a public sidewalk.

ZCA16-0002 City of Chandler / Sign Code Amendment (“redlined” version)

Draft date: April 19, 2017

- f) All signs shall be made of a rigid and durable material that will withstand the elements.
 - g) No sign shall be installed in the public right-of-way without first determining that no underground facilities will be encountered as required by Arizona Revised Statutes sections 40-360.22 et seq., also known as the Arizona Blue Stake Law.
3. Approval process and duration: Signs exceeding eight (8) feet in height shall require a sign permit in order to ensure the structural safety of said signs. Said permit shall be valid for two (2) years and shall be renewable on an annual basis thereafter. No permit shall be required for all other midsize temporary freestanding signs.
- G. Yard Signs (≤ 6 square feet)
1. Number of signs and location:
 - a) Each single family lot, model home cluster, and quasi-public or institutional use not located in a commercial or industrial district may place one (1) sign anywhere on the subject property, one (1) additional sign at each turning movement beginning at the subject property and extending for a maximum of one (1) mile distance from said property up to a maximum of ten (10) signs. Said signs shall be placed away from the street and no closer than five (5) feet from the curb behind the public sidewalk or no closer than five (5) feet from the edge of pavement when there is no public sidewalk. Said signs shall be displayed only on days when the property is open to the public (e.g. garage/yard sale, open house, and model home business hours).
 - b) Notwithstanding the foregoing, signs or notices required or posted by a government agency shall not be counted towards the number of signs permitted herein.
 - c) No sign shall be installed in the public right-of-way without first determining that no underground facilities will be encountered as required by Arizona Revised Statutes sections 40-360.22 et seq., also known as the Arizona Blue Stake Law.
 2. Area and height: Yard signs shall not exceed six (6) square feet in area nor exceed four (4) feet in height.
 3. Approval Process: No permit shall be required to display yard signs.

~~All temporary signs require a permit unless specifically exempted herein. The following temporary signs are prohibited unless expressly authorized within any of the subsections set out below and for the limited purposes stated within any such subsection:~~

- ~~• Non-public signs in public rights-of-way or on public property;~~
- ~~• Signs mounted on a building roof;~~
- ~~• Signs having intermittent or flashing illumination, animated or moving parts, or that emit sound;~~
- ~~• Banners, pennants, wind-driven spinners, streamers, balloons, flags, search lights, strobe lights, holographic projections, laser light displays, beacons, bandit, and inflatable signs;~~
- ~~• Signs imitating official traffic control signs, or any sign or device obscuring actual municipal or other public traffic control signs or devices;~~
- ~~• Signs mounted on, or applied to trees, utility poles, rocks, or City-owned property;~~
- ~~• Signs placed upon private property without the property owner's approval;~~
- ~~• Off-premises, portable signs or "A-frame" signs;~~

ZCA16-0002 City of Chandler / Sign Code Amendment (“redlined” version)

Draft date: April 19, 2017

- ~~• Business identification/advertising signs in single-family zoning districts.~~

~~39-10.1. Contractor signs. Contractor signs designating the contractor or subcontractor engaged in the construction or repair of a building or buildings on each parcel of land shall be allowed one (1) nonilluminated sign without a permit if in compliance with the following requirements.~~

~~A. The area of any single sign shall not exceed thirty-two (32) square feet in area nor exceed eight (8) feet in height.~~

~~B. The sign shall be removed within ten (10) days of completion of the work by the contractor or subcontractor on the property.~~

~~C. All contractors or subcontractors signs may be consolidated on one (1) sign. The area of a consolidated sign is calculated at six (6) square feet per contractor or subcontractor listed with a maximum sign area of one hundred (100) square feet for six (6) or more contractors. Said sign shall not exceed eight (8) feet in height or be located closer than ten (10) feet to a public right-of-way.~~

~~39-10.2. Development signs.~~

~~A. A sign permit shall be required for the erection of a development sign and is valid for a period of one (1) year.~~

~~B. One (1) single or double-faced freestanding sign is allowed upon the parcel of property to be developed unless it is a corner lot, in which case one (1) such sign per street front.~~

~~C. The face area of said sign shall not exceed thirty-two (32) square feet for the first acre or portion thereof. When the proposed parcel for development exceeds one (1) acre in size, the sign area may be increased four (4) square feet for each additional acre or portion thereof, not to exceed ninety-six (96) square feet.~~

~~D. These signs shall not exceed fifteen (15) feet in height or be located closer than ten (10) feet to a public right-of-way.~~

~~E. Such sign or signs shall be removed within ten (10) days after completion of the announced development of one (1) year, whichever is first.~~

~~39-10.3. Subdivision signs.~~

~~A. Permit required. A sign permit shall be required for the erection of a subdivision sign and is valid for two (2) years. Said permits are renewable on an annual basis thereafter.~~

~~B. Type and number. Subdivision signs shall be either single or double-faced. One (1) sign is permitted per parcel of property to be developed unless it is a corner parcel, in which case two (2) such signs are allowed, but only one (1) sign per street frontage. In the event the subdivision contains more than one (1) project, such as a detached single-family home project and a patio home project, and each has its own set of model homes, each such project shall be entitled to one (1) subdivision sign.~~

~~C. Size. Maximum height of said sign shall not exceed fifteen (15) feet, and said sign shall not exceed thirty-two (32) square feet for the first acre or portion thereof. For each additional acre in size, the combined area of the sign may be increased four (4) square feet up to a maximum of one hundred sixty (160) square feet.~~

~~D. Signs in retention areas. Said sign shall be placed no closer than fifteen (15) feet to a public right-of-way, except that a subdivision sign may be permitted to be located in a water retention area provided that:~~

- ~~1. The retention area fronts an arterial street;~~

ZCA16-0002 City of Chandler / Sign Code Amendment (“redlined” version)

Draft date: April 19, 2017

- ~~2. The retention area has been dedicated and improved by the subdivision requesting the sign location;~~
- ~~3. The sign applicant provides acceptable liability insurance and holds the City harmless from any consequences of the location;~~
- ~~4. No special or unusual maintenance problems are created by the location; and~~
- ~~5. The location and installation of the sign is effected in a manner consistent with the intent of this section.~~

~~39-10.4. Subdivision direction sign.~~

- ~~A. A subdivision direction sign is a temporary sign which is designed and erected for the purpose of directing the public to a recorded residential subdivision for the sale of homes or lots thereon. These signs may be placed on property other than the subdivision property.~~
- ~~B. These signs require a sign permit and shall be removed within ten (10) days after the use they advertise is fulfilled, or upon eighty (80) percent completion of the subdivision.~~
- ~~C. Sign area shall not exceed thirty-two (32) square feet.~~
- ~~D. One (1) sign per project per mile is allowed or where there is a change in direction, provided such sign is located on property with the owner's permission.~~
- ~~E. No sign shall be more than ten (10) feet in height or closer than ten (10) feet to the public right-of-way.~~

~~39-10.5. Grand opening signs.~~

- ~~A. A grand opening sign is a temporary sign which calls attention to a new business or institutional use. These signs are allowed in any zone in which the commercial, industrial or institutional uses are permitted.~~
- ~~B. The sign or signs shall not be displayed for more than thirty (30) days.~~
- ~~C. Only one (1) grand opening sign shall be allowed per use.~~

~~39-10.6 Model home signs.~~

- ~~A. A model home sign is a form of temporary sign which identifies an unoccupied new home used as a demonstrator to advertise and promote sales of other homes within the recorded subdivision. Each model home may have one (1) identification sign not to exceed six (6) square feet in area, or two (2) such signs if located on a corner lot. These signs may be freestanding and do not require a permit.~~
- ~~B. These signs shall be made of solid, non-flexible material. Off-premises portable signs or "A-frame" signs are not allowed.~~
- ~~C. No such sign shall be located on a public right-of-way.~~
- ~~D. No sign permit is required.~~

~~39-10.7 Open house signs.~~

- ~~A. An open house sign is a portable, temporary sign to direct traffic to a home for sale, and shall not exceed a maximum height of three (3) feet and a maximum area of six (6) square feet and may be freestanding.~~

ZCA16-0002 City of Chandler / Sign Code Amendment ("redlined" version)

Draft date: April 19, 2017

- ~~B. The sign may be double-faced but shall not be illuminated.~~
- ~~C. The sign shall not be placed in any public right-of-way.~~
- ~~D. The sign shall be used only when sales personnel are at the home being advertised for sale.~~
- ~~E. A maximum of four (4) such signs for each home or group of homes in the subdivision shall be allowed.~~
- ~~F. These signs shall be made of solid, non-flexible material. Off-premises portable signs or "A-frame" signs are allowed.~~
- ~~G. No sign permit is required.~~

~~39-10.8. Political signs.~~

- ~~A. Political and campaign signs on behalf of candidates for public office or urging action on primary, general or special election ballots are permitted in all zoning districts and do not require a permit.~~
- ~~B. The display is limited to sixty (60) days immediately preceding any primary, general or special elections to which they refer, and shall be removed ten (10) days following said election.~~
- ~~C. The person, party or parties responsible for the erection or distribution of any such signs shall be jointly and individually liable for their removal.~~
- ~~D. The total sign area in residential districts shall not exceed ten (10) square feet, nor five (5) feet in height. Total sign area in commercial and industrial district shall not exceed fifty (50) feet in area, nor eight (8) feet in height.~~
- ~~E. The sign shall not be placed in or upon any public right-of-way and/or including utility poles in said right-of-way.~~

~~39-10.9 Real estate signs.~~

- ~~A. The property being advertised for lease, sale or rental shall be limited to one (1) such sign on each lot or parcel of land, except when it is a corner lot, in which case two (2) such signs may be used, one (1) sign for each street front. Said sign shall be removed within ten (10) days of sale, lease or rental.~~
- ~~B. These signs shall be made of solid, non-flexible material. Off-premises portable signs or "A-frame" signs are not allowed.~~
- ~~C. No such sign shall be placed in any public right-of-way.~~
- ~~D. Residential signs shall not exceed a maximum of height of six (6) feet above grade, and a maximum of sixteen (16) square feet in area. Said signs shall not be illuminated. No sign permit is required.~~
- ~~E. In property zoned for commercial or industrial use, a permit is required for a real estate sign and such sign shall be allowed as follows:
 - ~~1. Parcels containing two (2) acres or less are allowed a sign not to exceed A maximum area of sixteen (16) square feet.~~
 - ~~2. Parcels containing less than ten (10) acres but more than two (2) are allowed a sign not to exceed thirty two (32) square feet.~~~~

ZCA16-0002 City of Chandler / Sign Code Amendment ("redlined" version)

Draft date: April 19, 2017

~~3. Parcels containing ten (10) acres or more are allowed a sign not to exceed fifty (50) square feet and may be illuminated, but any illuminated sign shall be indirect or internal only.~~

~~4. Maximum height of all such signs shall not exceed twelve (12) feet.~~

~~39-10.10 Significant Event Signs.~~

~~A. A "significant event sign" is a temporary sign displayed on property used or zoned for any use other than a single-family residence and which displays any type of event that is unique or significant to the business located upon the property. Such events include, but are not limited to, an anniversary, special sale, change in ownership or management, or similar event. A permit for a "significant event sign" is not the same as a special event permit under Chapter 32 of the Chandler City Code.~~

~~B. Significant event signs are subject to all of the following requirements:~~

~~1. Such sign(s) may include a banner, pennant, wind-driven spinner, tear-drop banner, streamer, balloon, flag, or inflatable.~~

~~2. Use of such sign(s) shall be limited to no more than twenty-one (21) cumulative days within each six (6) month period in a calendar year.~~

~~3. A sign permit is required and must be displayed that is visible to the public during the allowed time of the permit.~~

~~4. No such sign(s) shall be placed in any public right-of-way.~~

~~5. An application fee established by Council resolution shall be charged for each sign permit issued under this subsection.~~

~~6. Off-premises, portable signs or "A-frame" signs are not allowed.~~

~~39-10.11 "Open During Construction" Signs.~~

~~A. An "open during construction sign" is a temporary sign displayed on property used or zoned for any use other than a single-family residence and which calls attention to an existing business or institutional use located on property adjacent to or otherwise affected by a City funded or designated construction project.~~

~~B. No sign permit is required.~~

~~C. The transportation and development director shall verify a property's eligibility.~~

~~D. Open during construction signs are subject to all of the following requirements:~~

~~1. Only one (1) single- or double-faced open during construction sign shall be allowed per use.~~

~~2. Such sign may include a banner, pennant, or tear-drop banner.~~

~~3. Off-premises, portable signs or "A-frame" signs are not allowed.~~

~~4. The face area of said sign shall not exceed sixteen (16) square feet.~~

~~5. The sign shall be removed promptly following the completion of the City funded or designated construction project.~~

~~39-11. Revocation of permits.~~

ZCA16-0002 City of Chandler / Sign Code Amendment (“redlined” version)

Draft date: April 19, 2017

~~The Zoning Administrator shall have the authority to revoke any permit which has been granted when it has been determined by the Director of Planning and Development or the Zoning Administrator that the sign authorized by the permit has been constructed or is being maintained in violation of the permit.~~

~~A. Notice of the planning and development decision to revoke a sign permit shall be served on the holder of the permit by:~~

- ~~1. Delivering a copy of the notice to the holder of the permit, mail return receipt requested, to the last-known post office address of the holder of the permit; and~~
- ~~2. Leaving a copy of the notice with any person in charge of the premises and a copy mailed to the property owner; or~~
- ~~3. In the event no such person can be found on the premises, by affixing a copy of the notice in a conspicuous position at or near the entrance to the premises.~~

~~B. The holder of the permit may appeal the decision of the Director of Planning and Development to the Board of Adjustment. This appeal must be made within thirty (30) days from the date when the notice was served.~~

~~C. If no appeal has been filed by the end of the thirty-day appeal period, then the permit is revoked and the sign is illegal. The Director of Planning and Development shall then initiate the procedure for the removal of the illegal sign.~~

~~39-12. Removal of signs.~~

~~The Director of Planning and Development is hereby authorized to require the removal of any illegal sign as defined by this chapter.~~

~~A. Before bringing action to require the removal of any illegal sign, the Director of Planning and Development shall give written notice to the owner of the sign or the owner of the premises on which the sign is located. The notice shall state the reasons for removal, listing the deficiencies or defects in the sign with reasonable definiteness, and the violations charged. The notice shall include what repairs if any will make such an installation conform to the requirements of this chapter. The notice shall specify that the sign must be removed or made to conform with the provisions of this chapter within the time period listed below. Service of notice may be given personally to the owner or lessee, or by certified mail addressed to the owner or lessee at the address specified in the permit or last-known address.~~

~~B. The period of notice for permanent sign as defined by this chapter shall be thirty (30) days. The period of notice for temporary signs as defined by this chapter shall be three (3) working days.~~

~~C. The re-erection of any sign or substantially similar sign on the same premises after a removal notice has been issued shall be deemed a continuance of the original violation.~~

~~D. If the owner or lessee of the premises where the sign is located has not complied with this chapter by the end of the notice period, the Director of Planning and Development shall certify the violations to the City Attorney for prosecution. or any other remedy allowed by law.~~

~~39-13. Emergency removal or repair.~~

~~A. The Director of Planning and Development is hereby authorized to cause the immediate removal or repair of any sign or signs found to be unsafe, defective, or a traffic hazard to the extent that it creates an immediate and emergency hazard to persons or property. Actual notice to the property owner or lessee shall not be required. The Director shall make a reasonable effort to notify the property owner or lessee that the defective and unsafe sign must be removed or repaired immediately.~~

ZCA16-0002 City of Chandler / Sign Code Amendment (“redlined” version)

Draft date: April 19, 2017

~~B. All actual costs incurred by the Director of Planning and Development in the removal or repair of said sign shall be paid by the owner of the sign or the owner of the premises where the sign is located. Action for recovery may be brought by the City Attorney upon proper certification to him/her by the Director of Planning and Development.~~